

# BIONICLE®

CENDOX V1

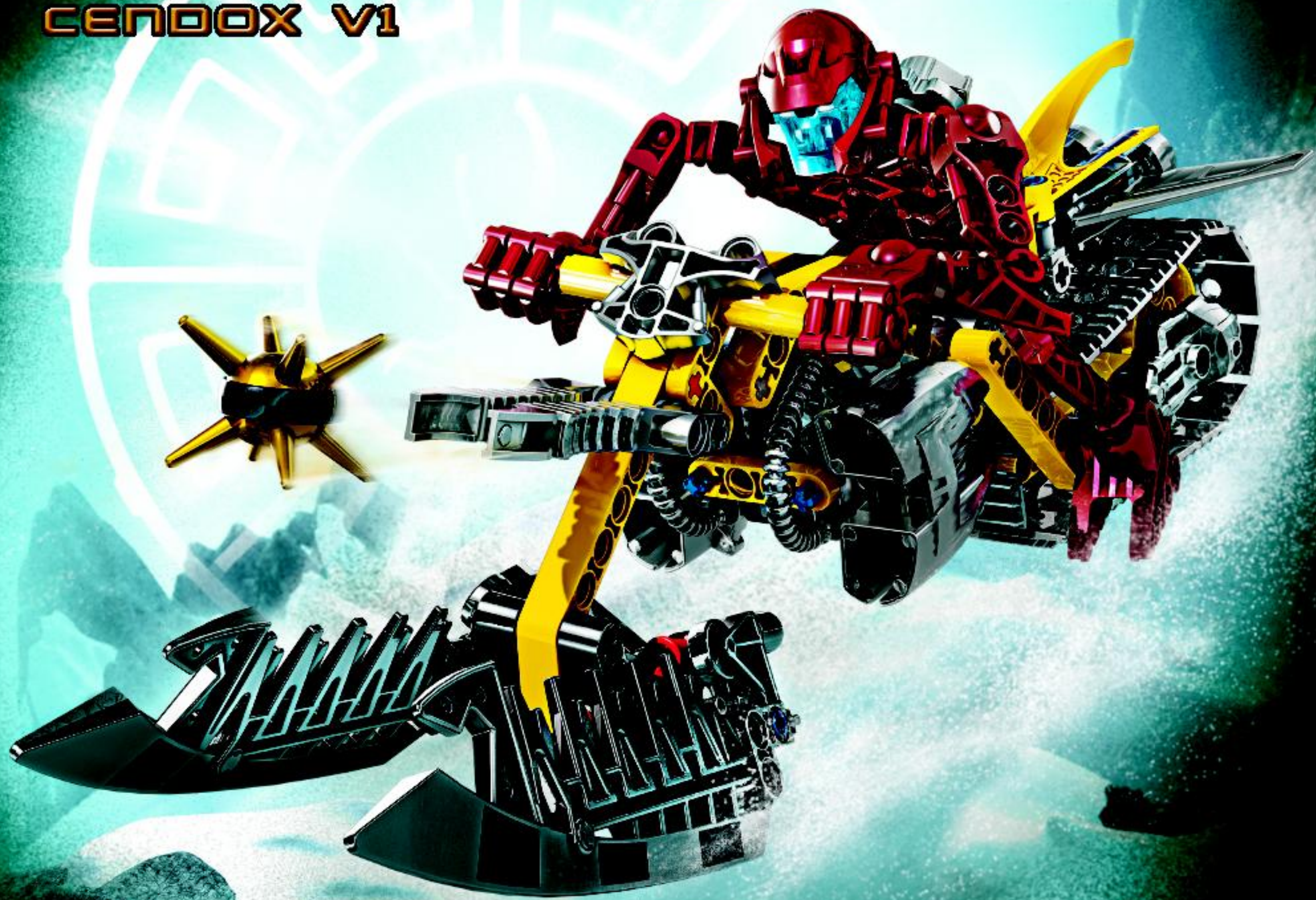

8992

LEGO



1

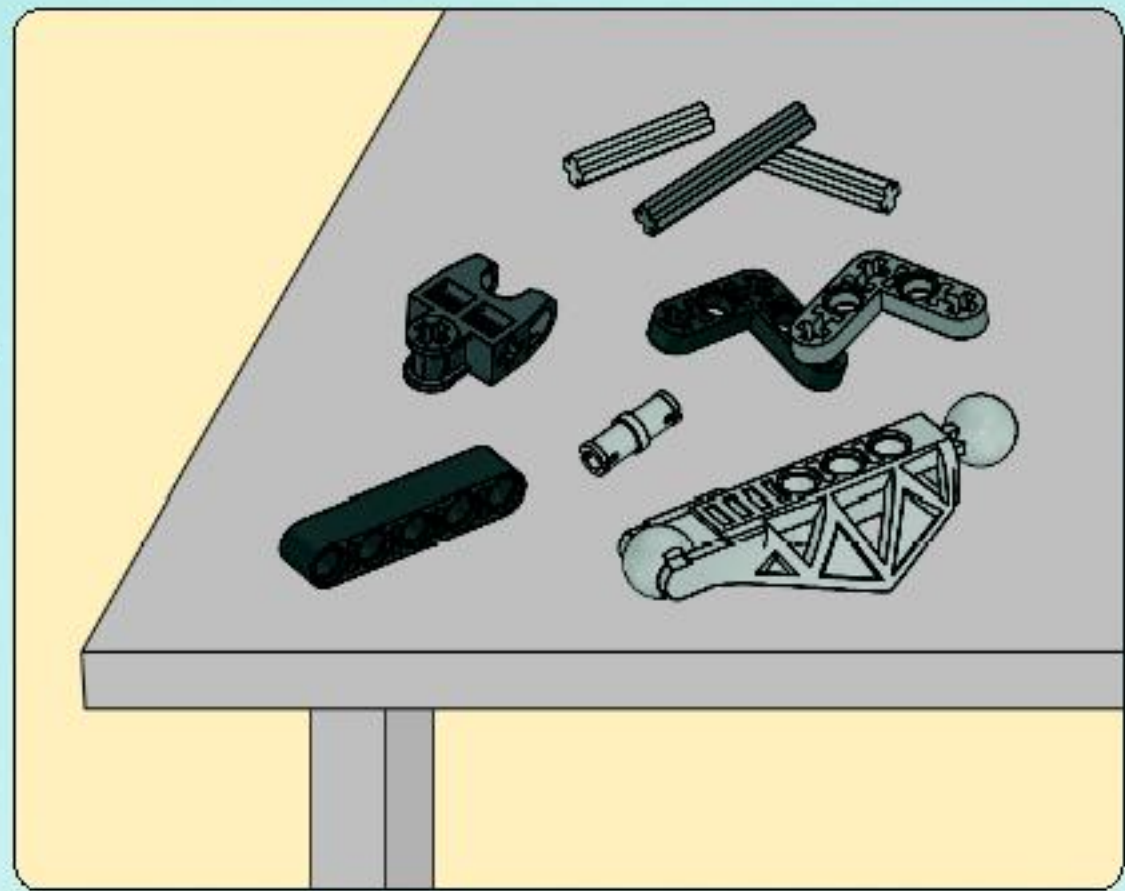
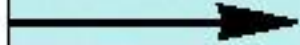

2

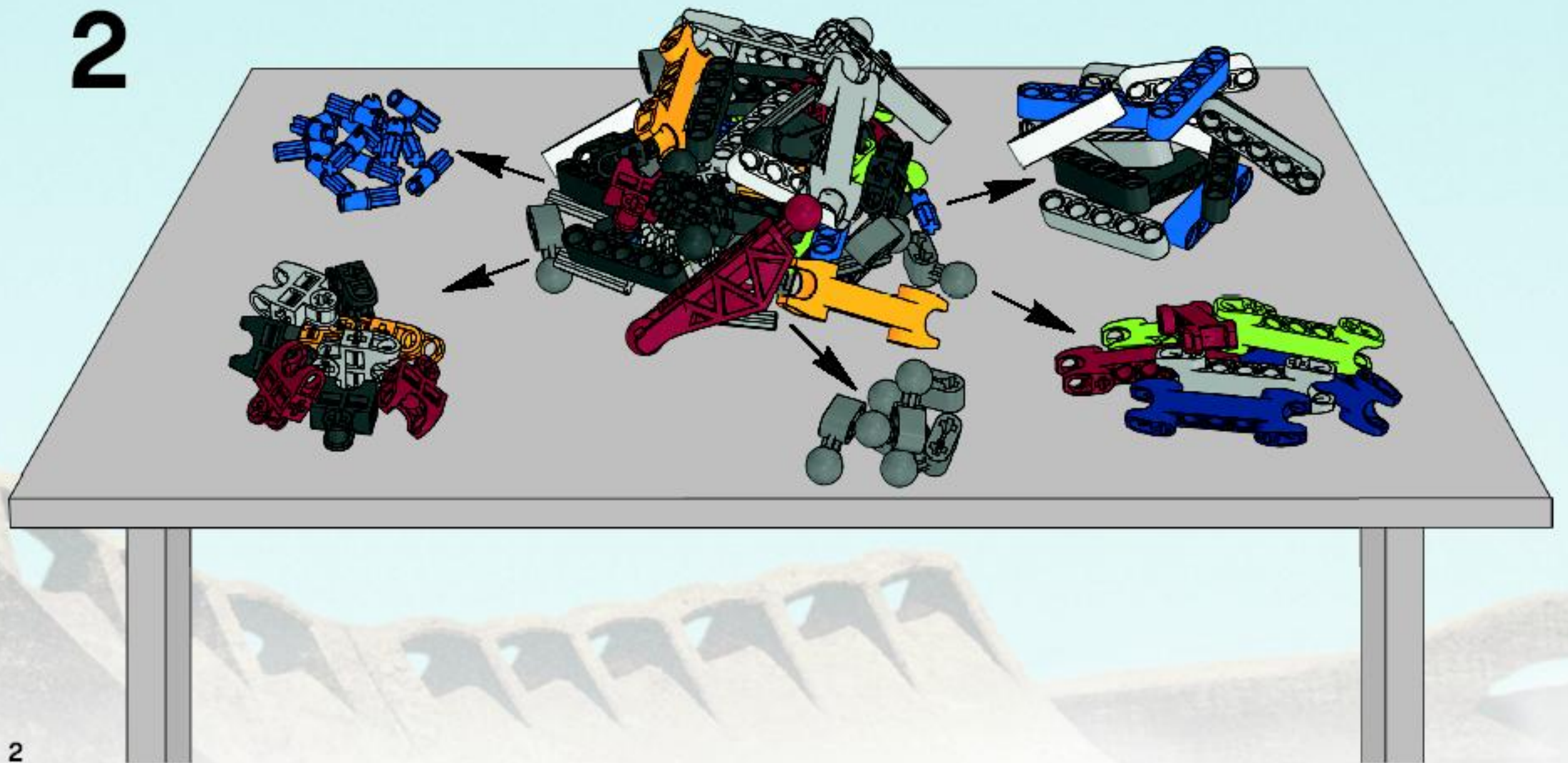

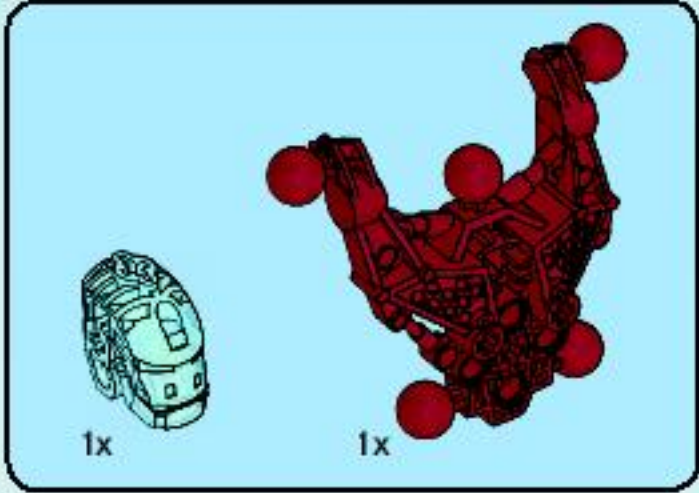
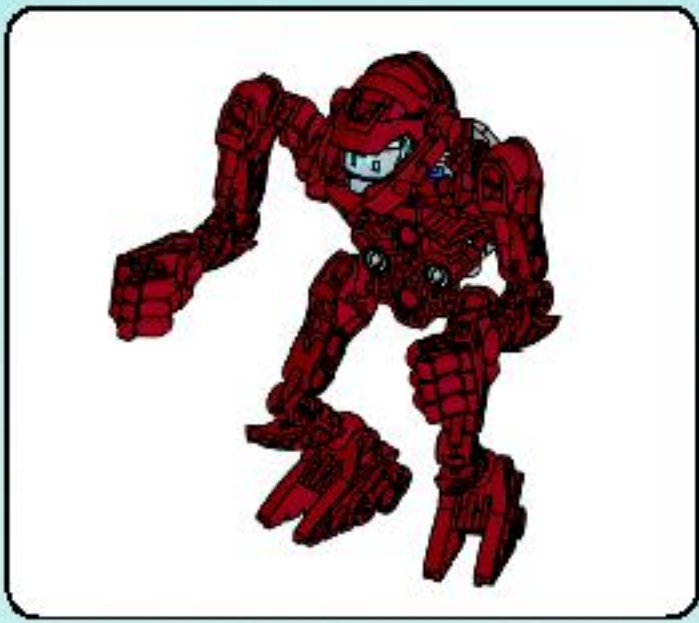

1

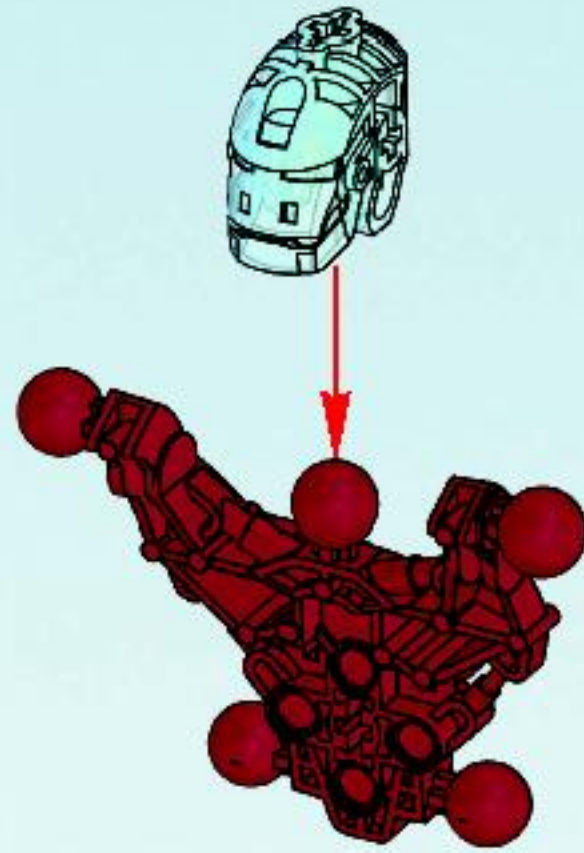



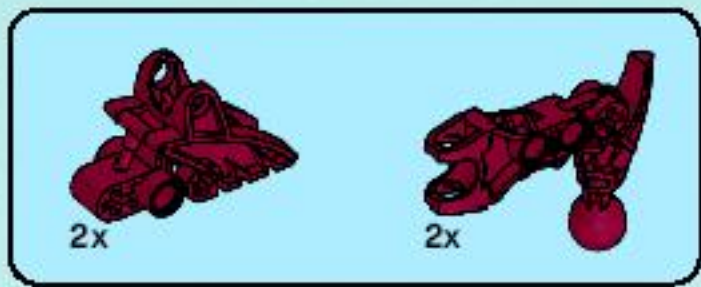

2

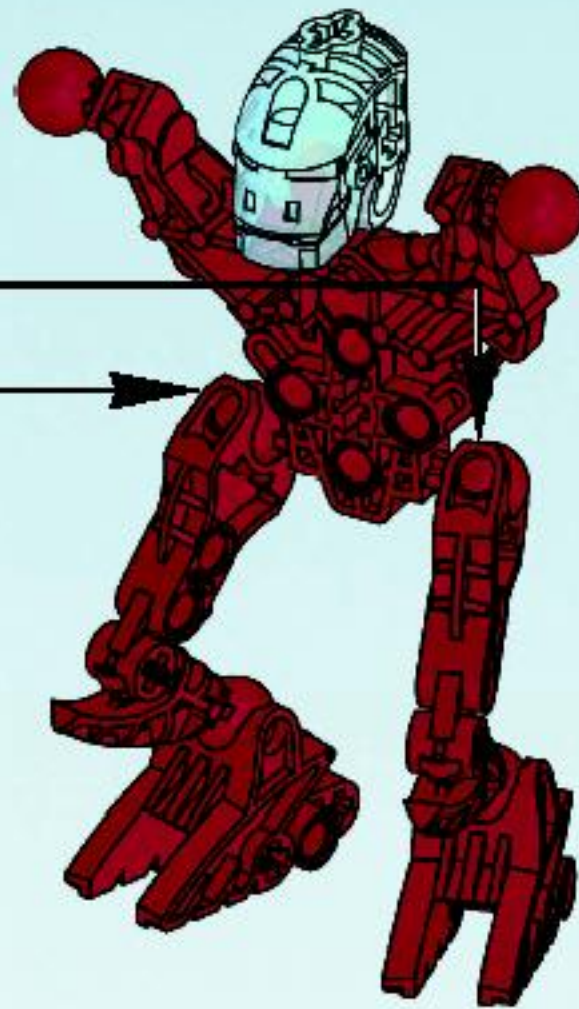
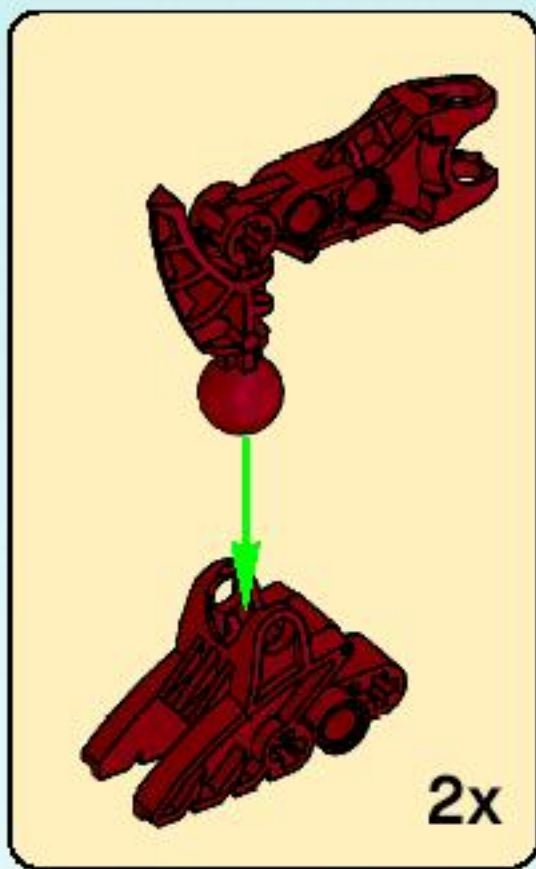

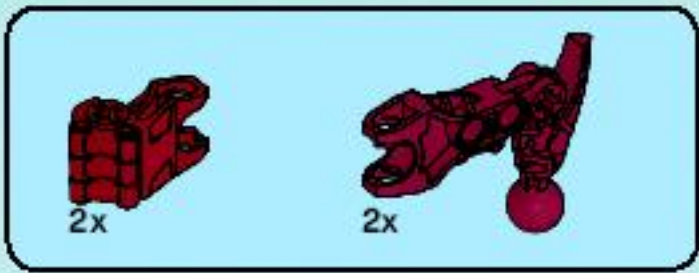

3

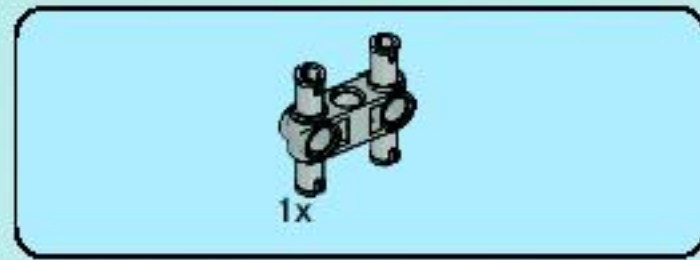
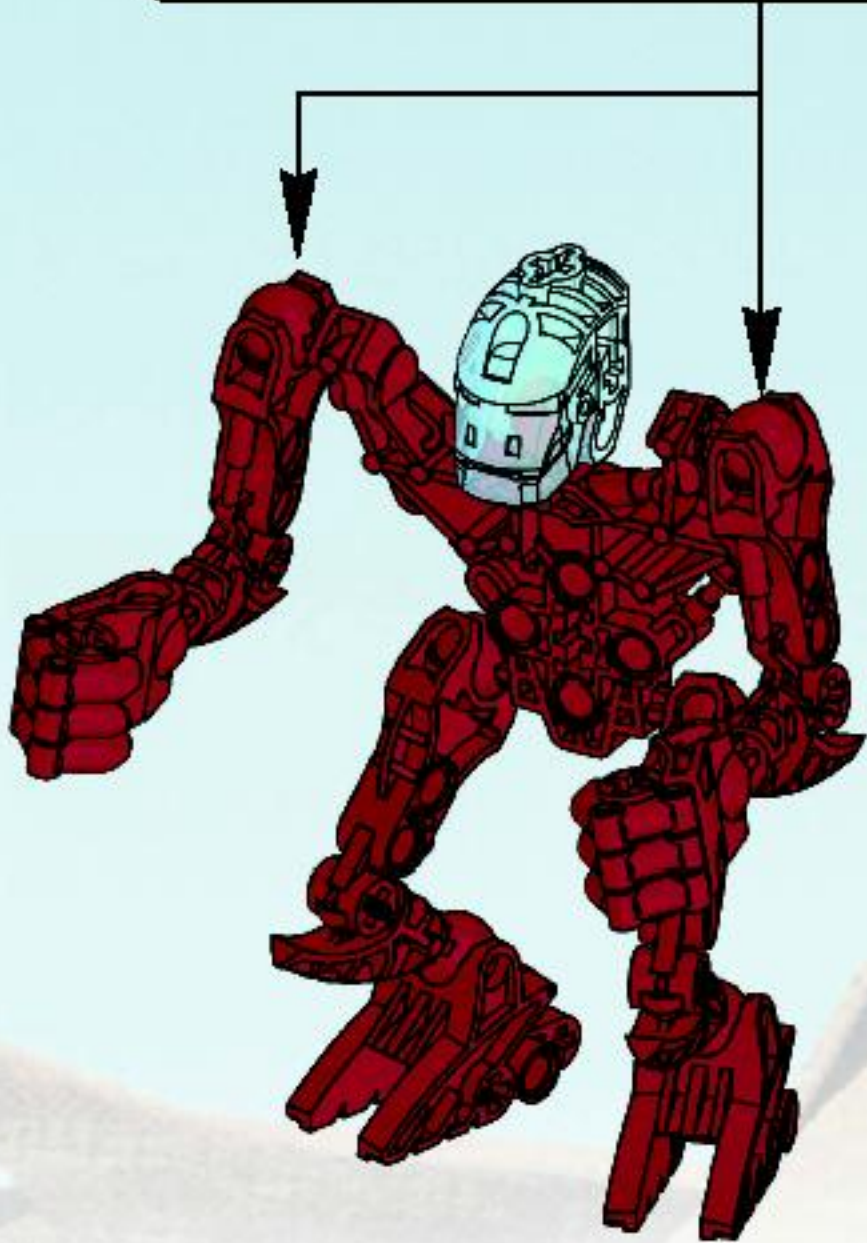
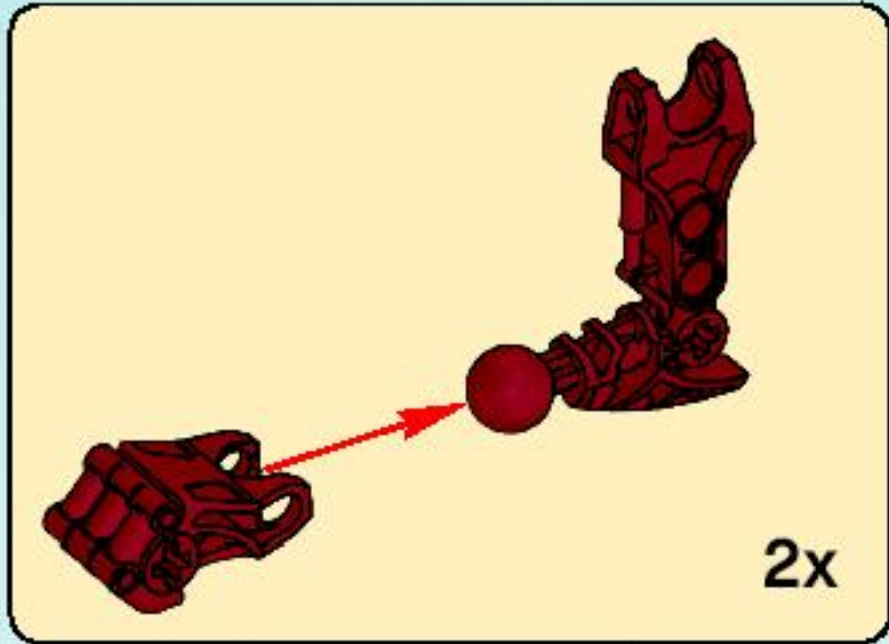

4







5

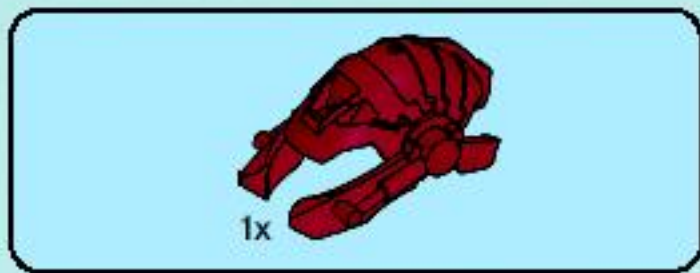
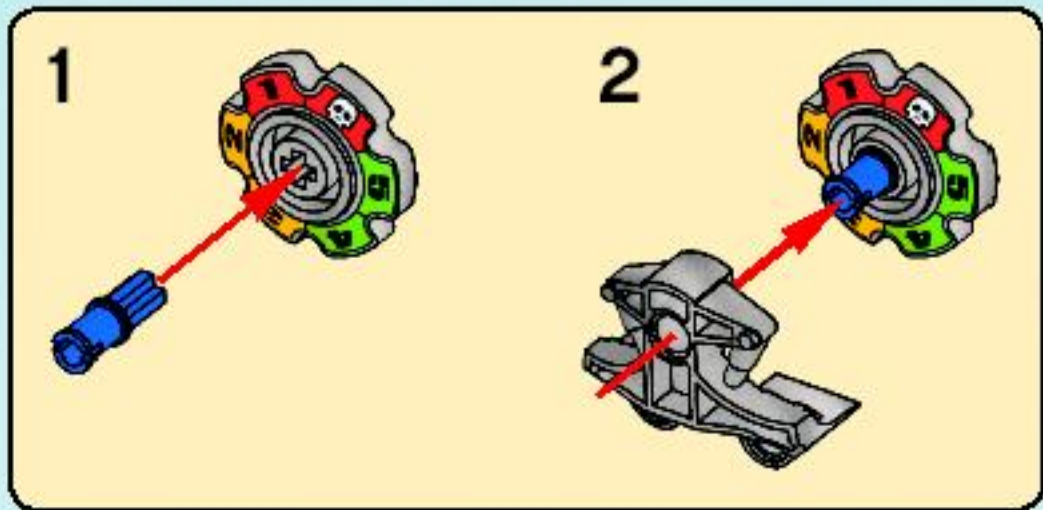

6

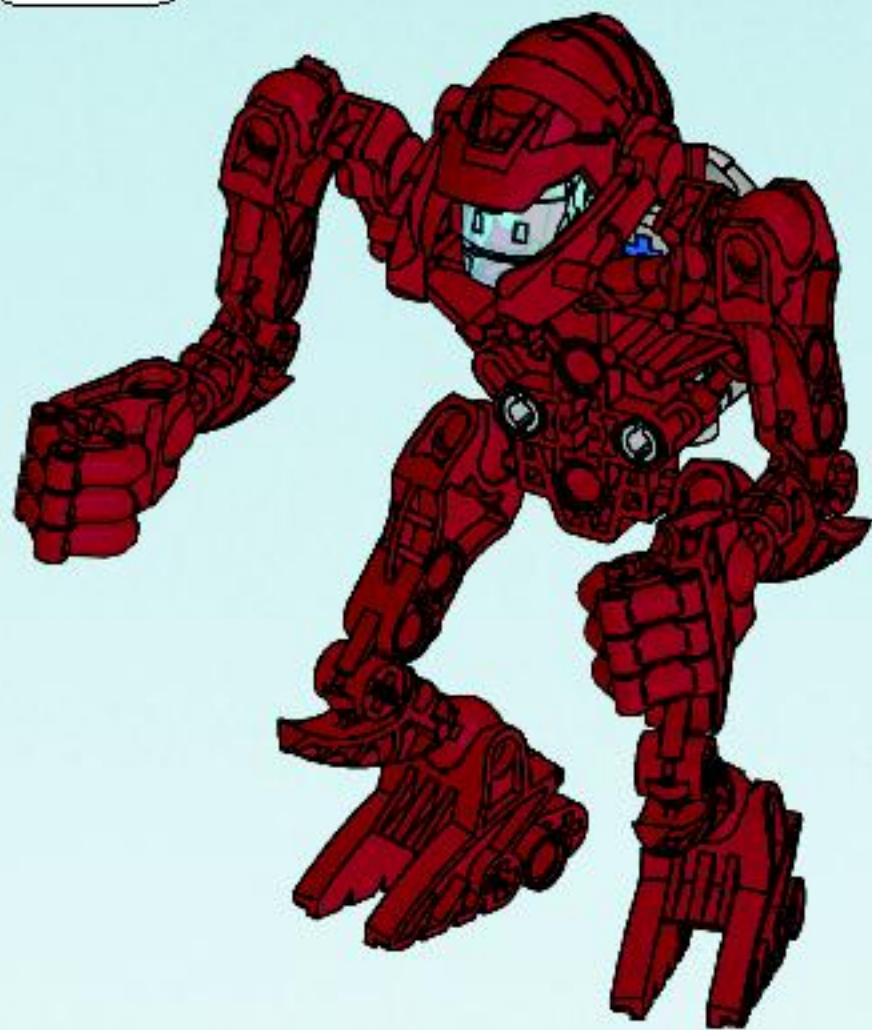



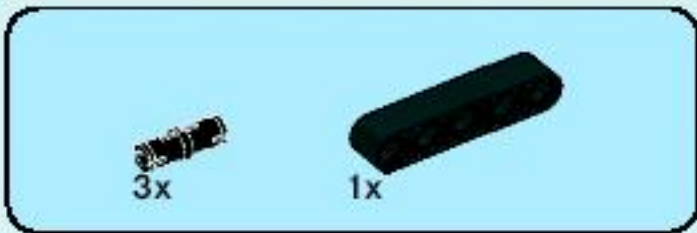
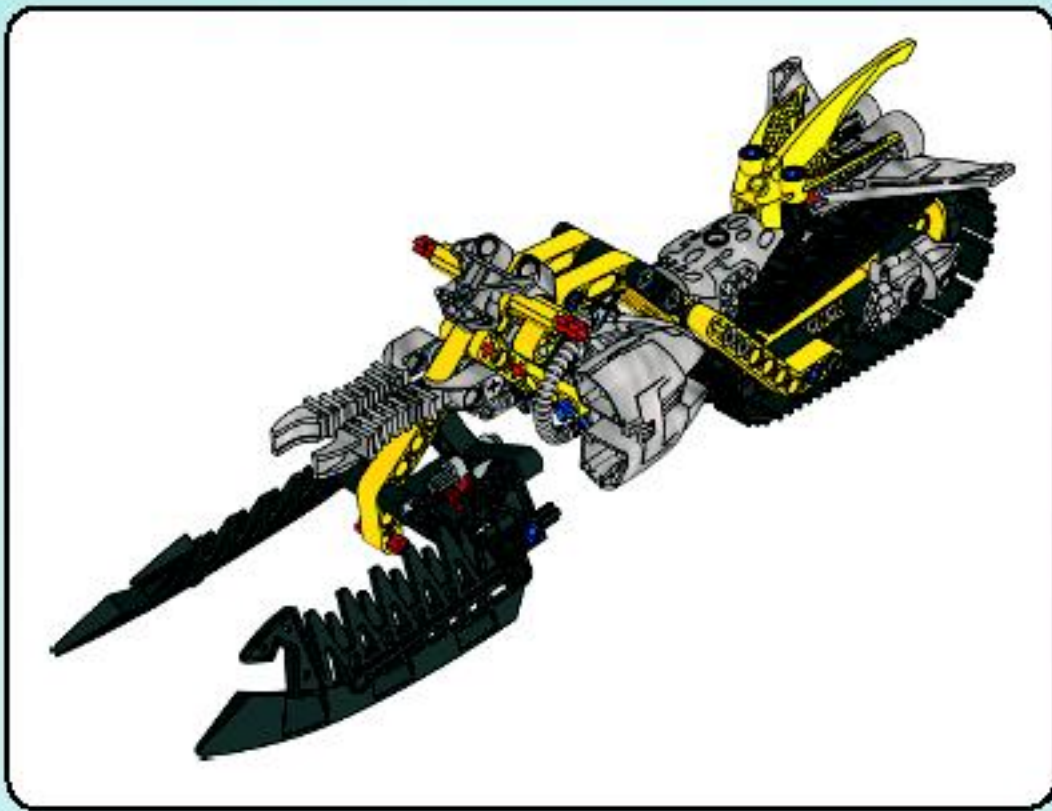

1

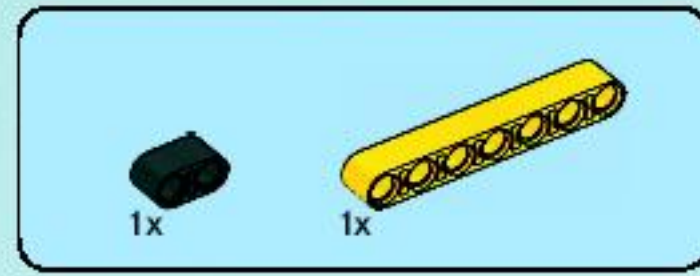
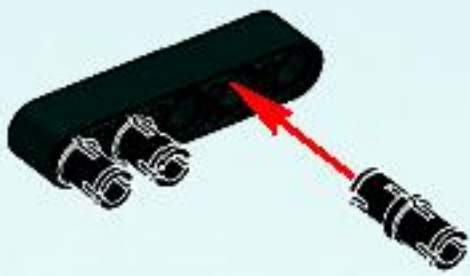

2

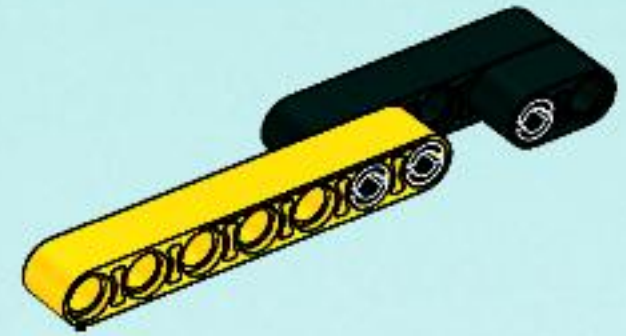

3

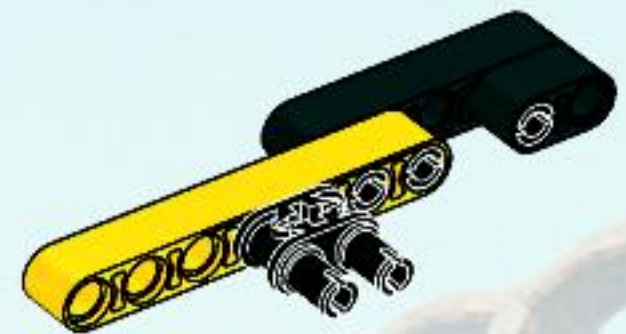



4

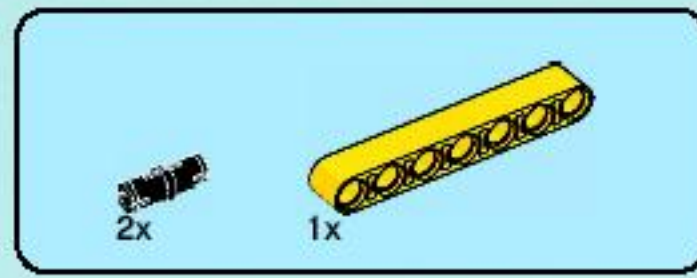
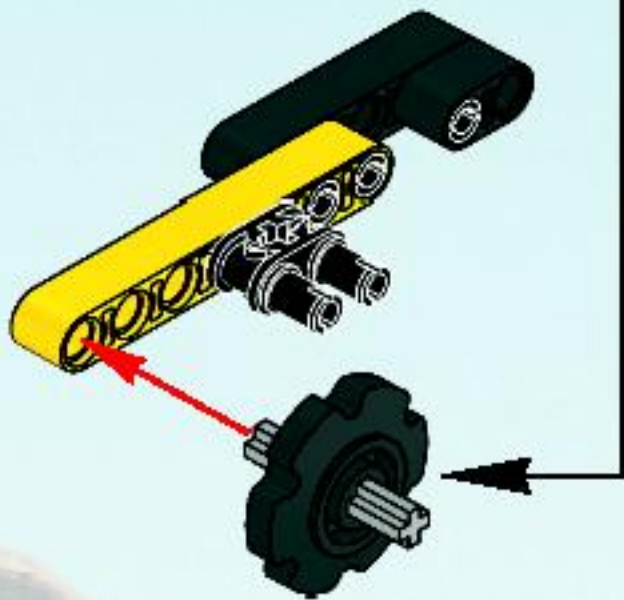
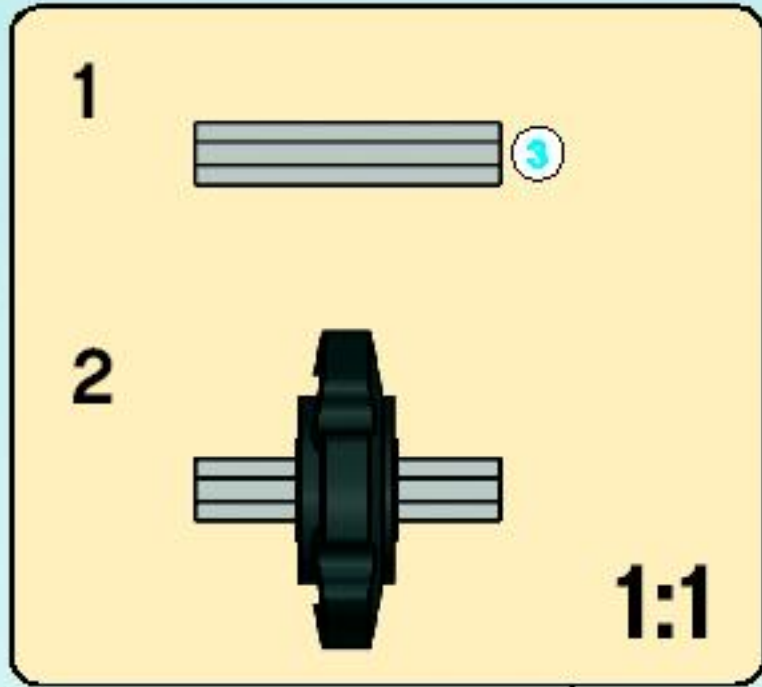

5

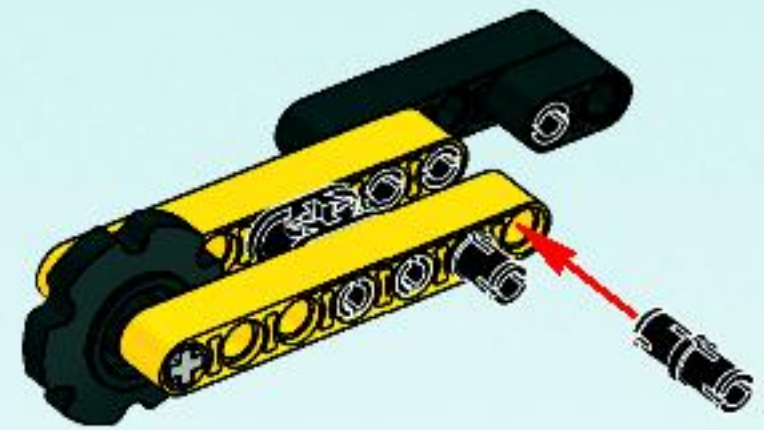



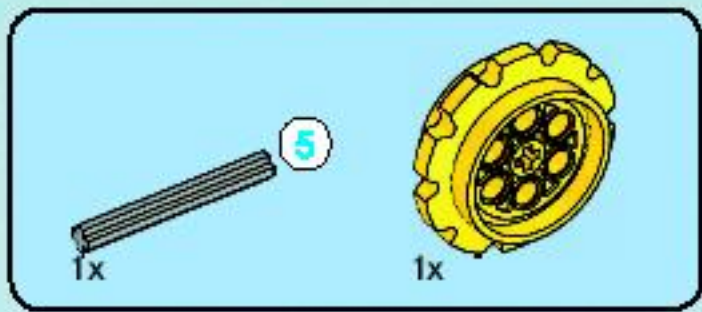

6

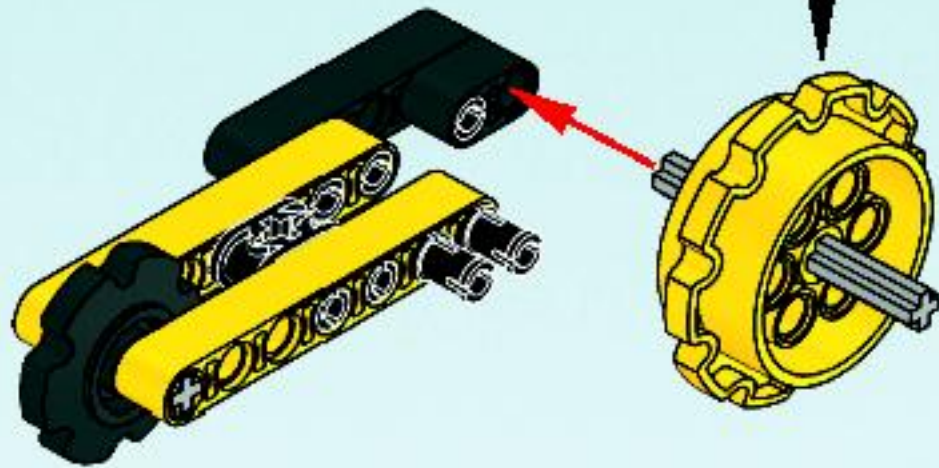
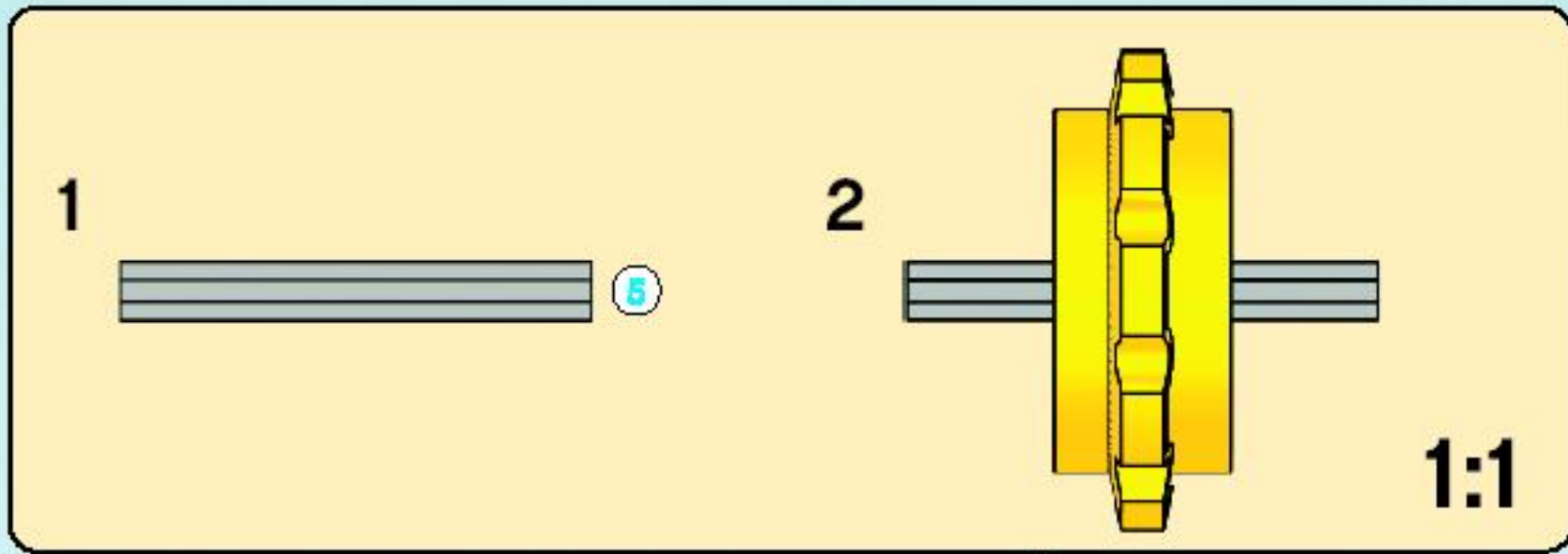



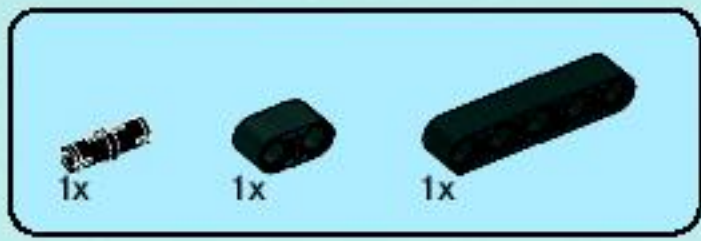

7

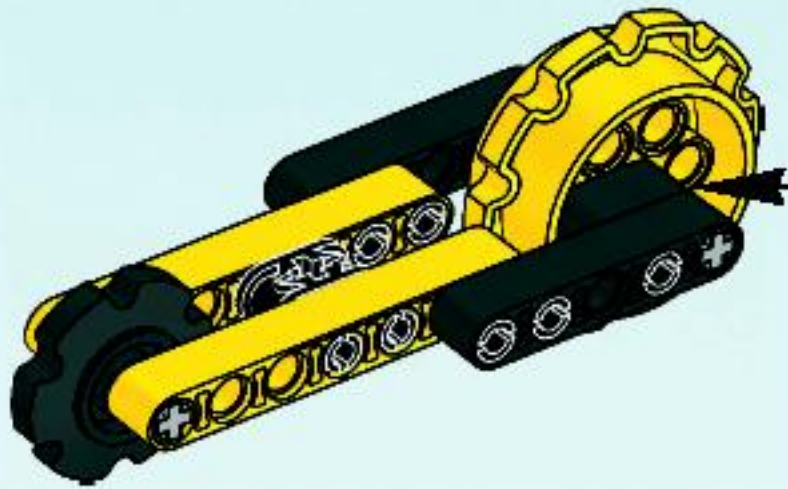
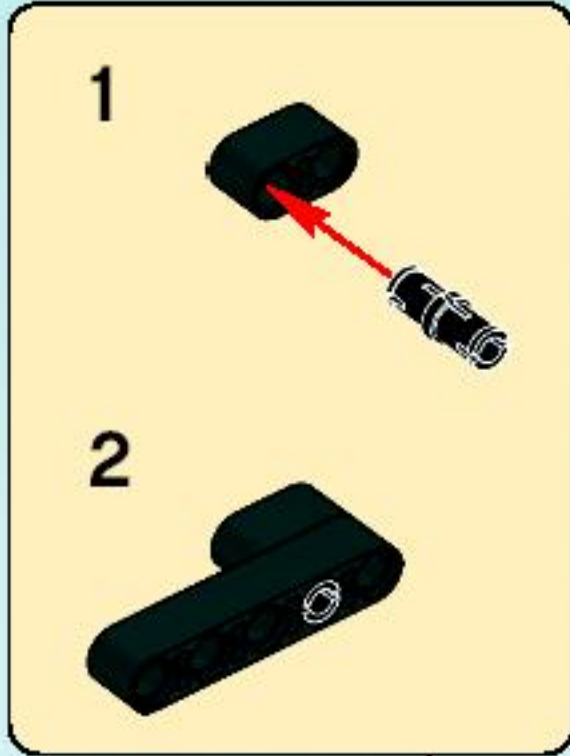

8

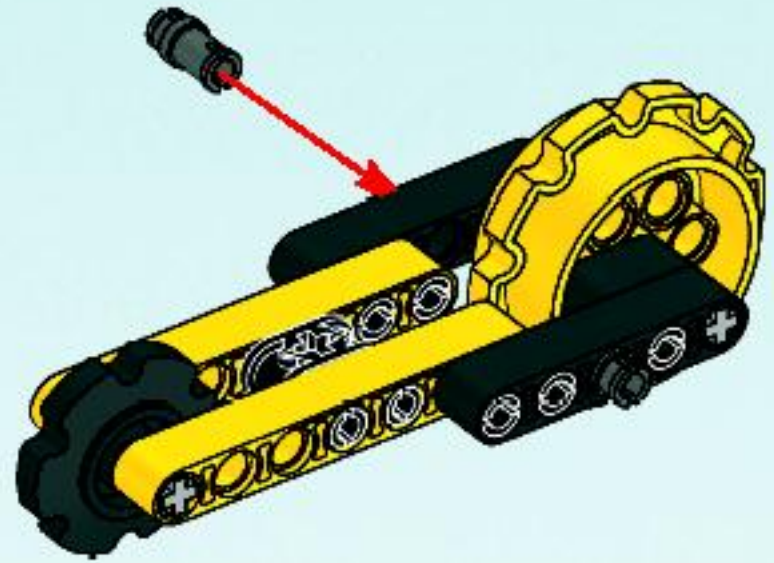





9

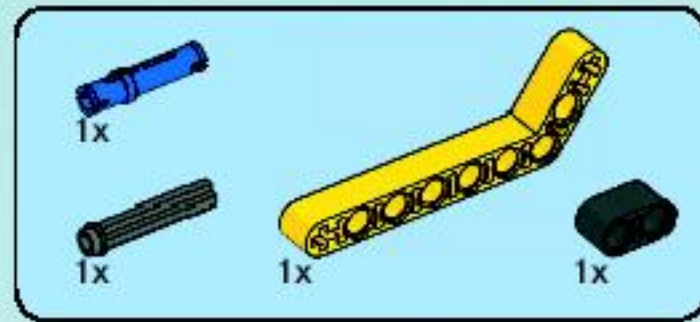
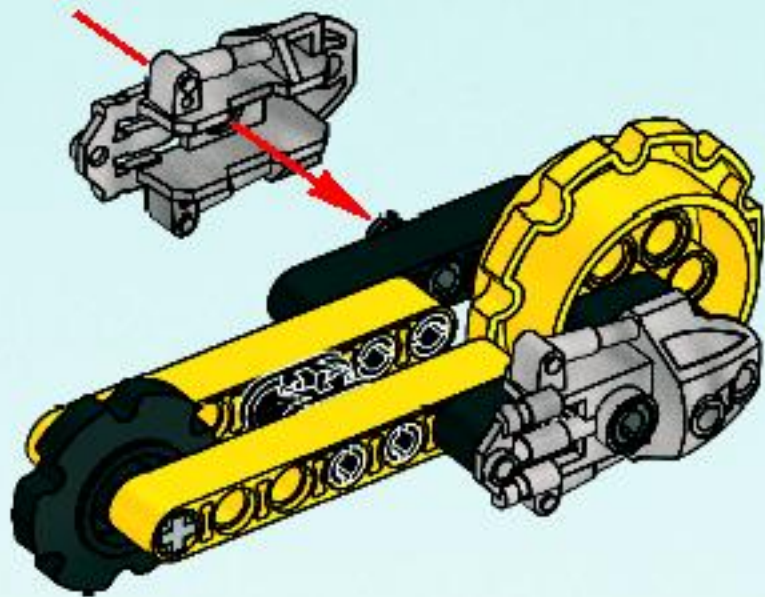

10

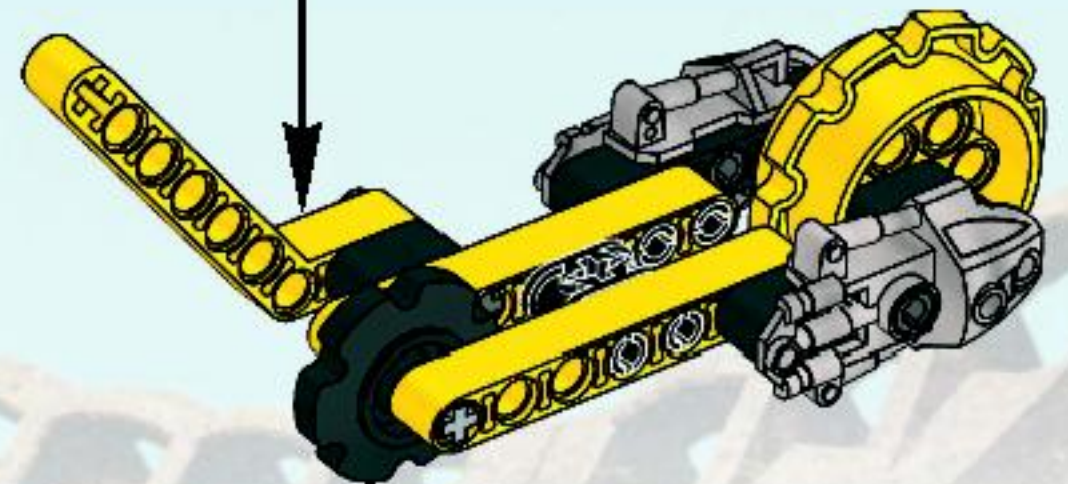
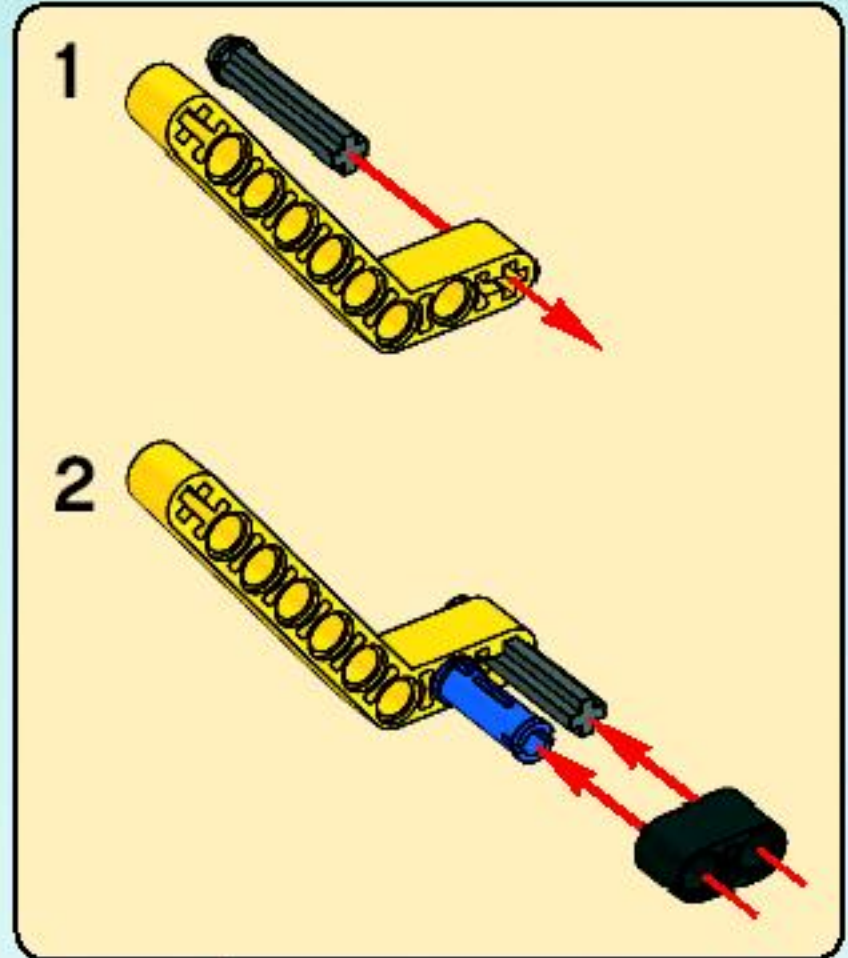





20x

11

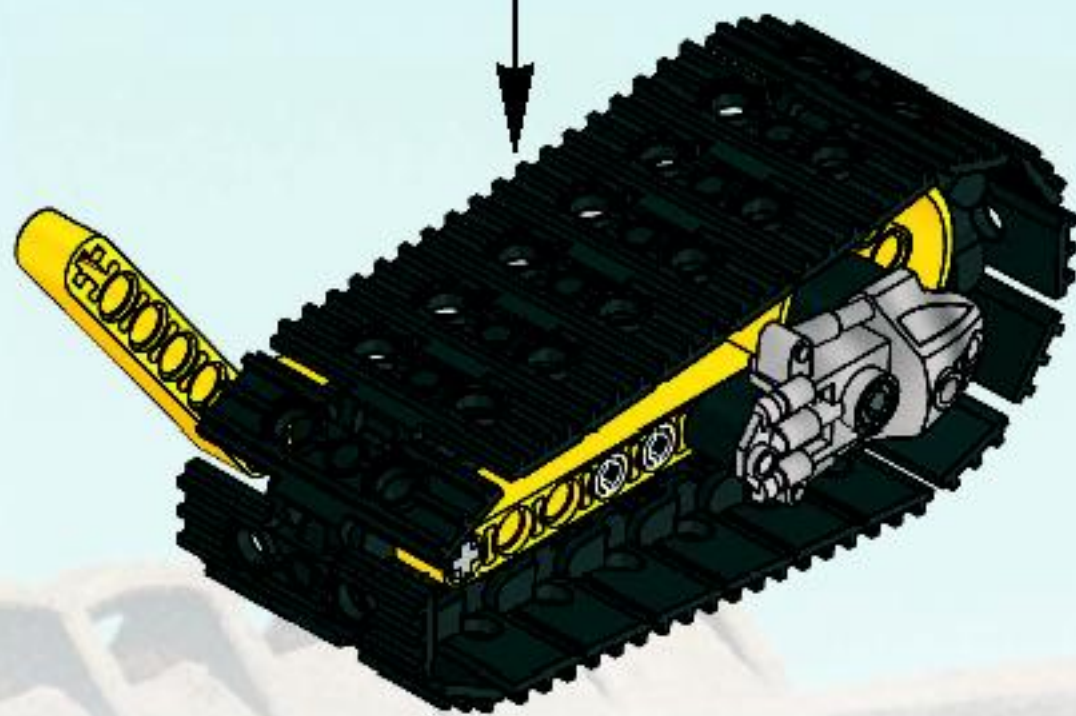
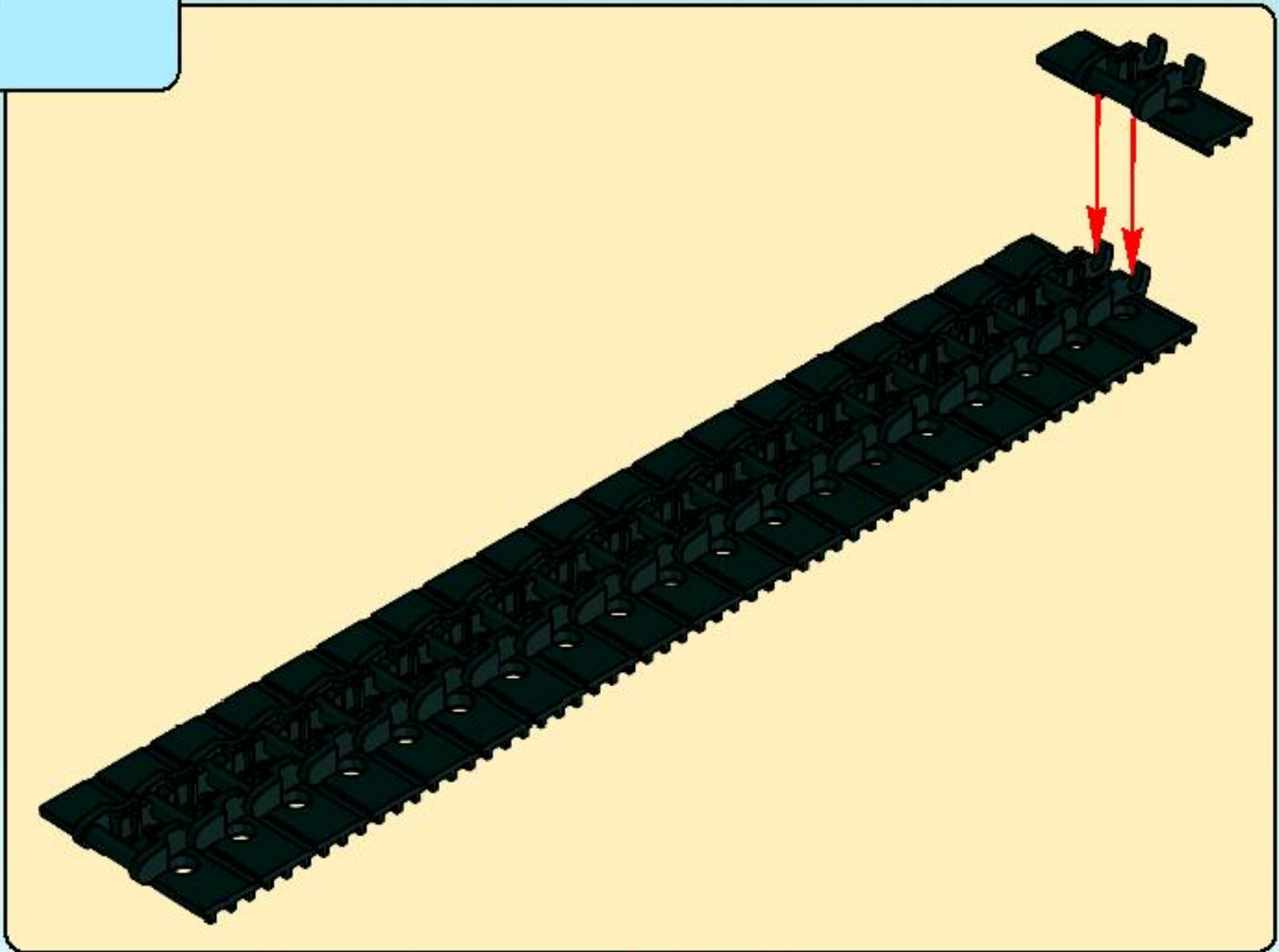



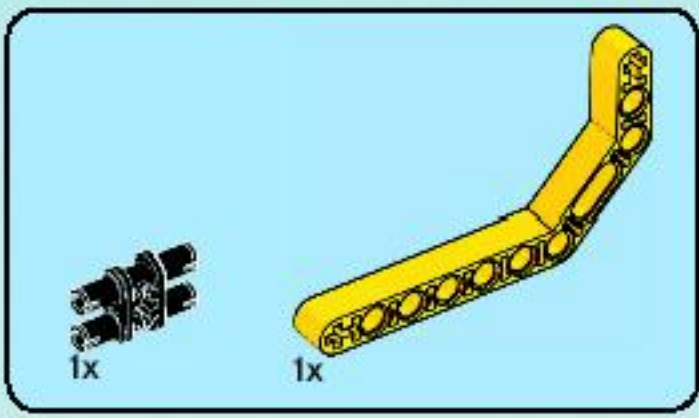

12

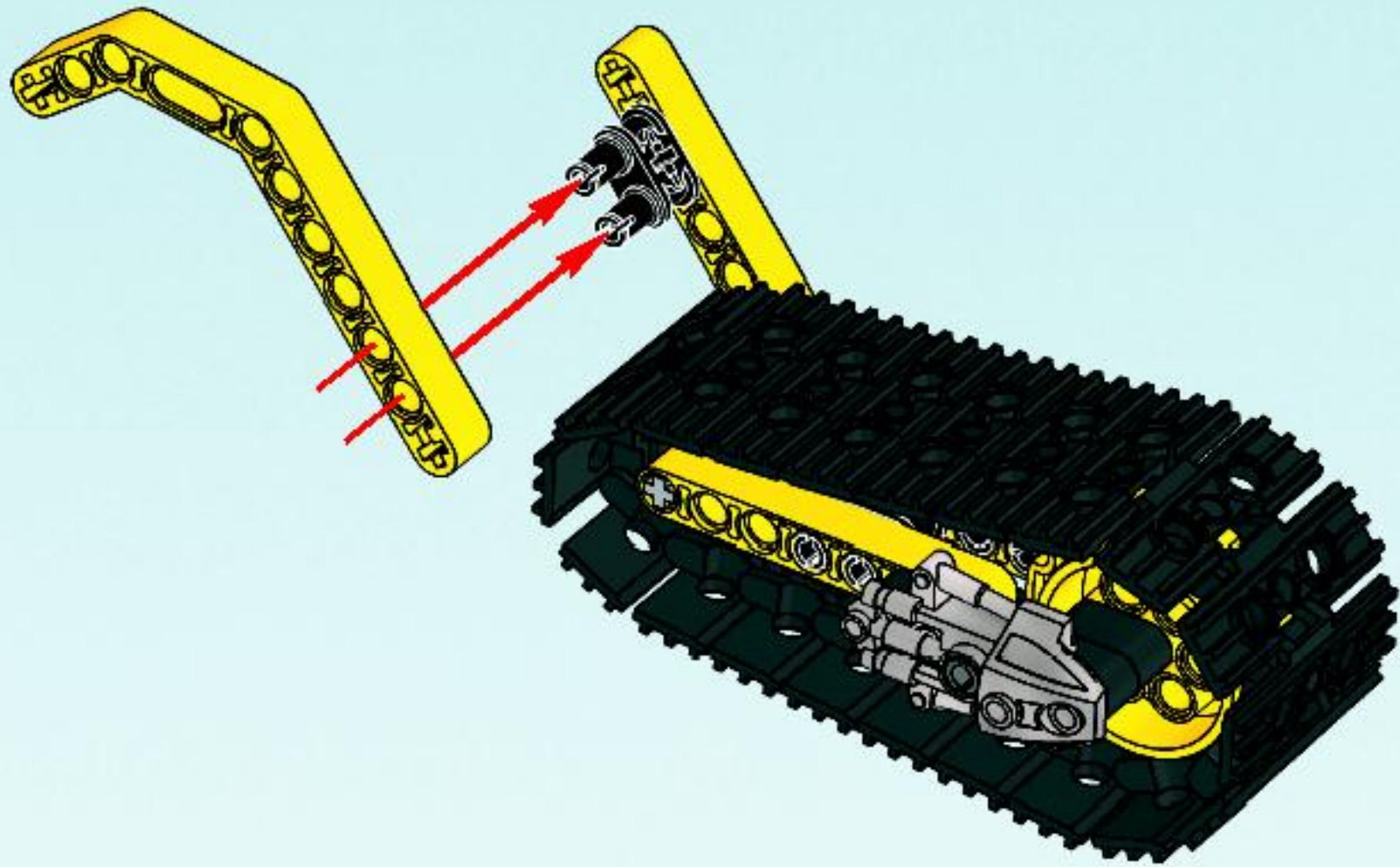





13

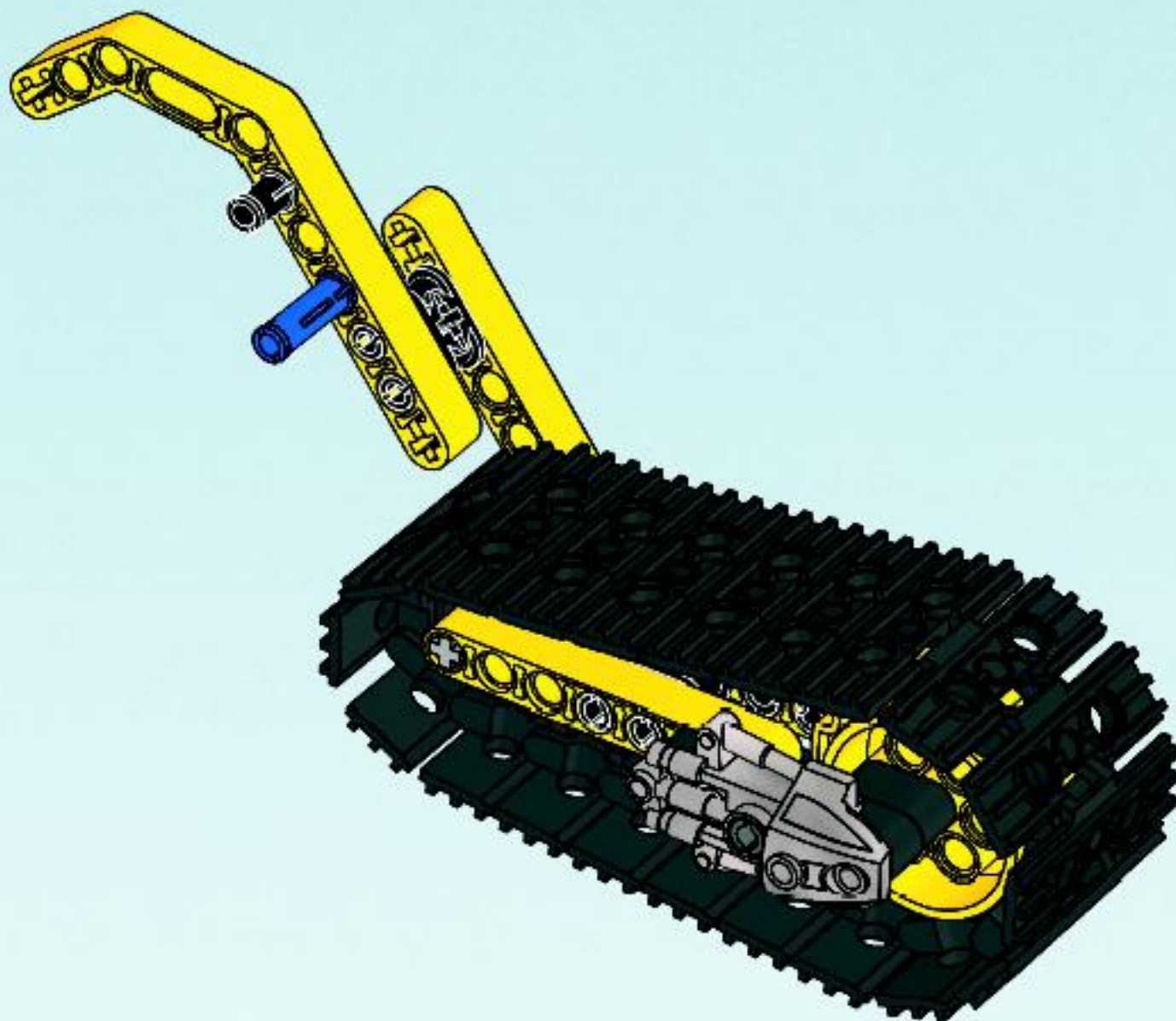



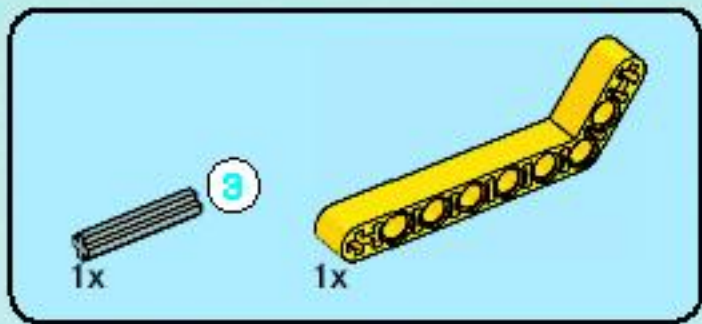

14

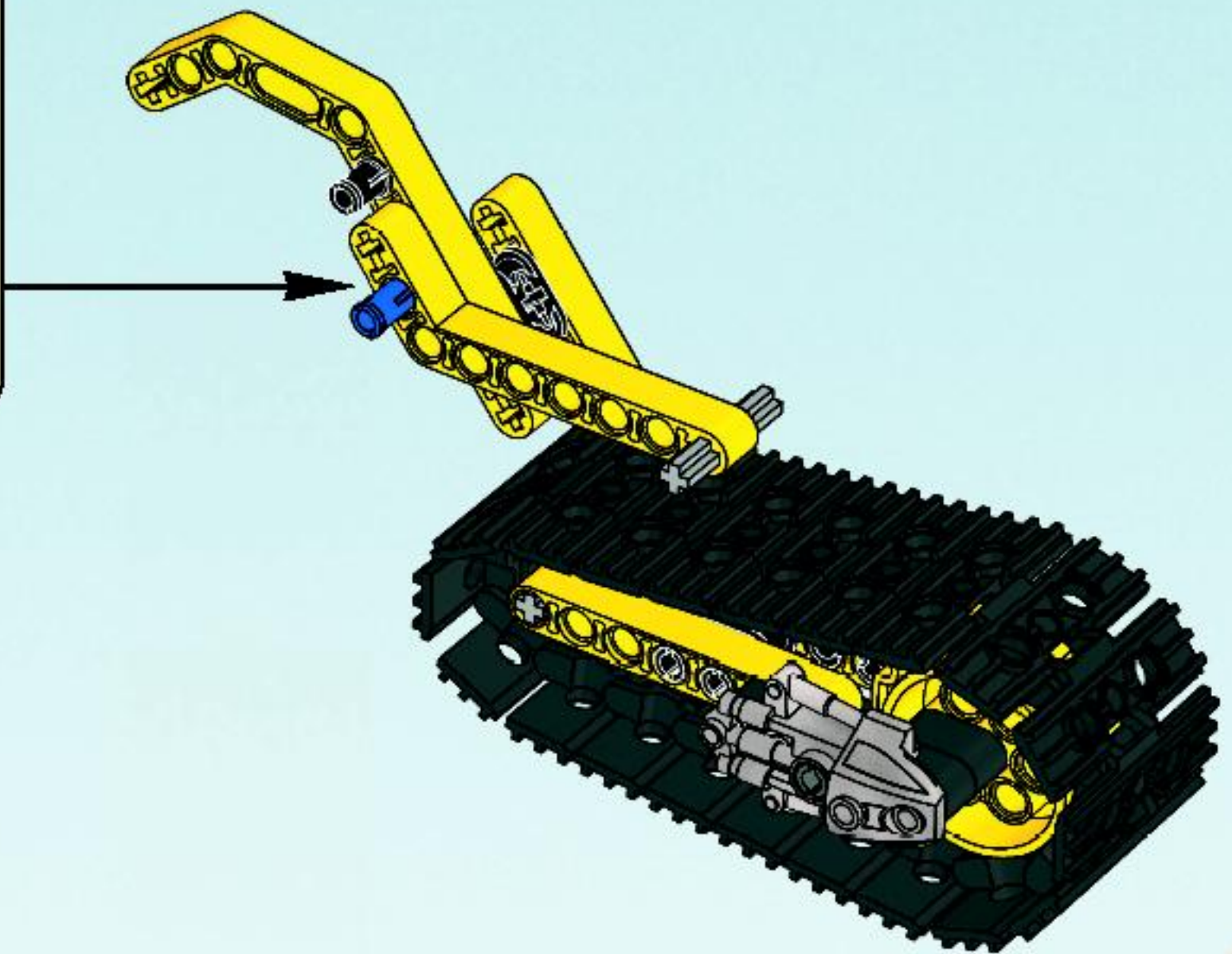
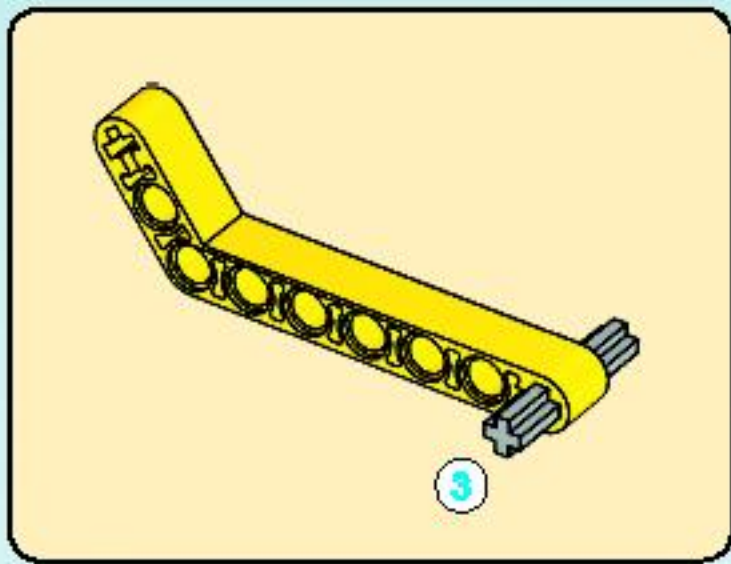



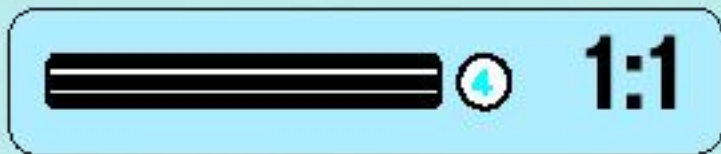

15

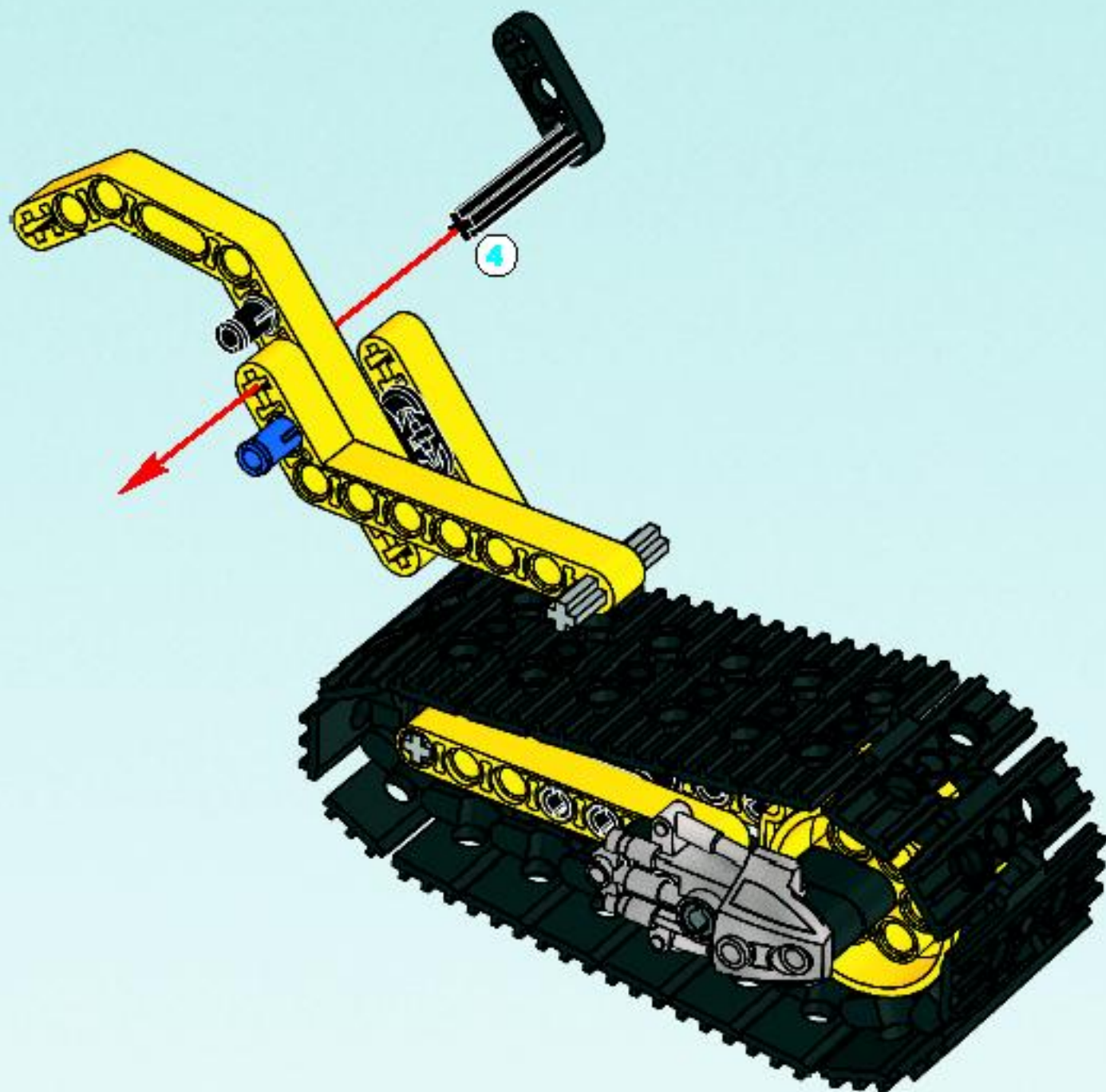



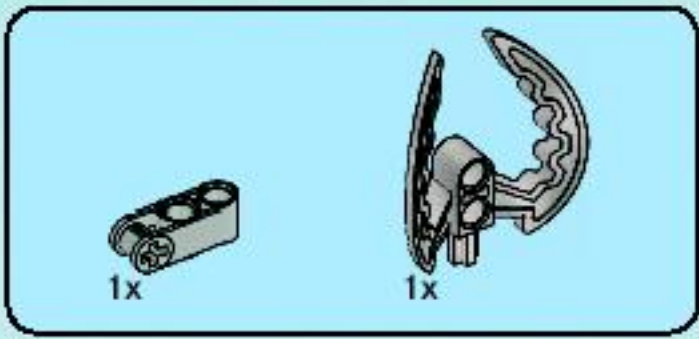

# 16

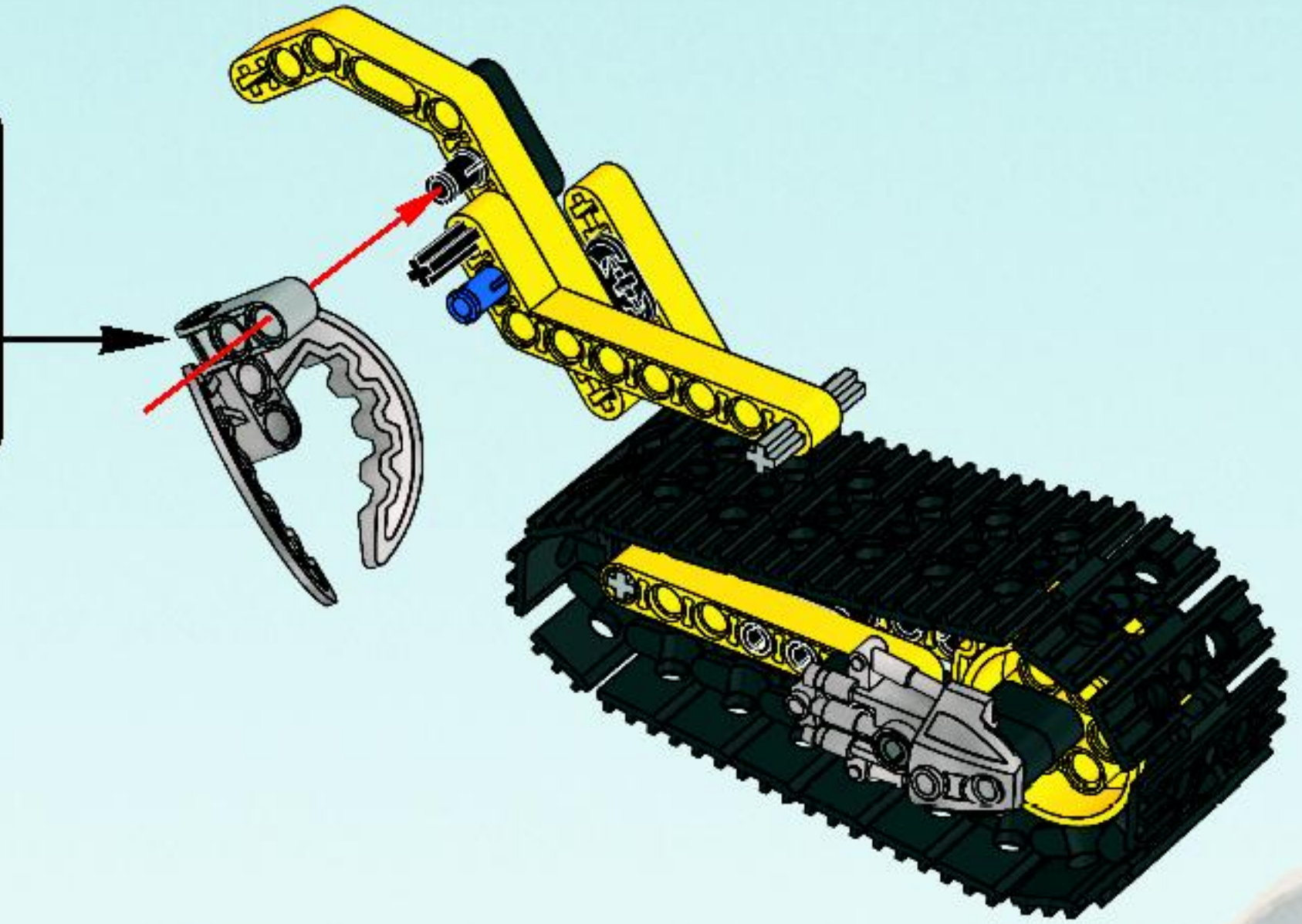
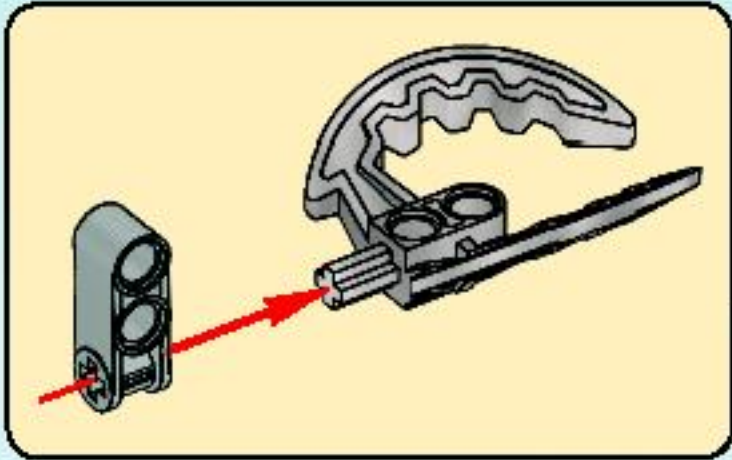



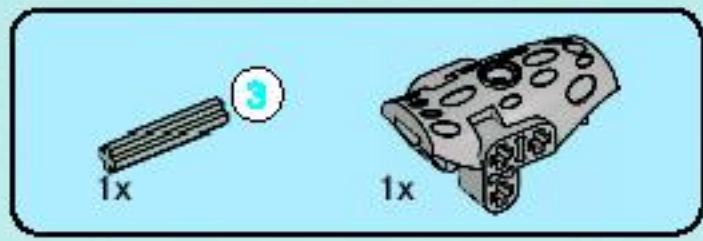

17

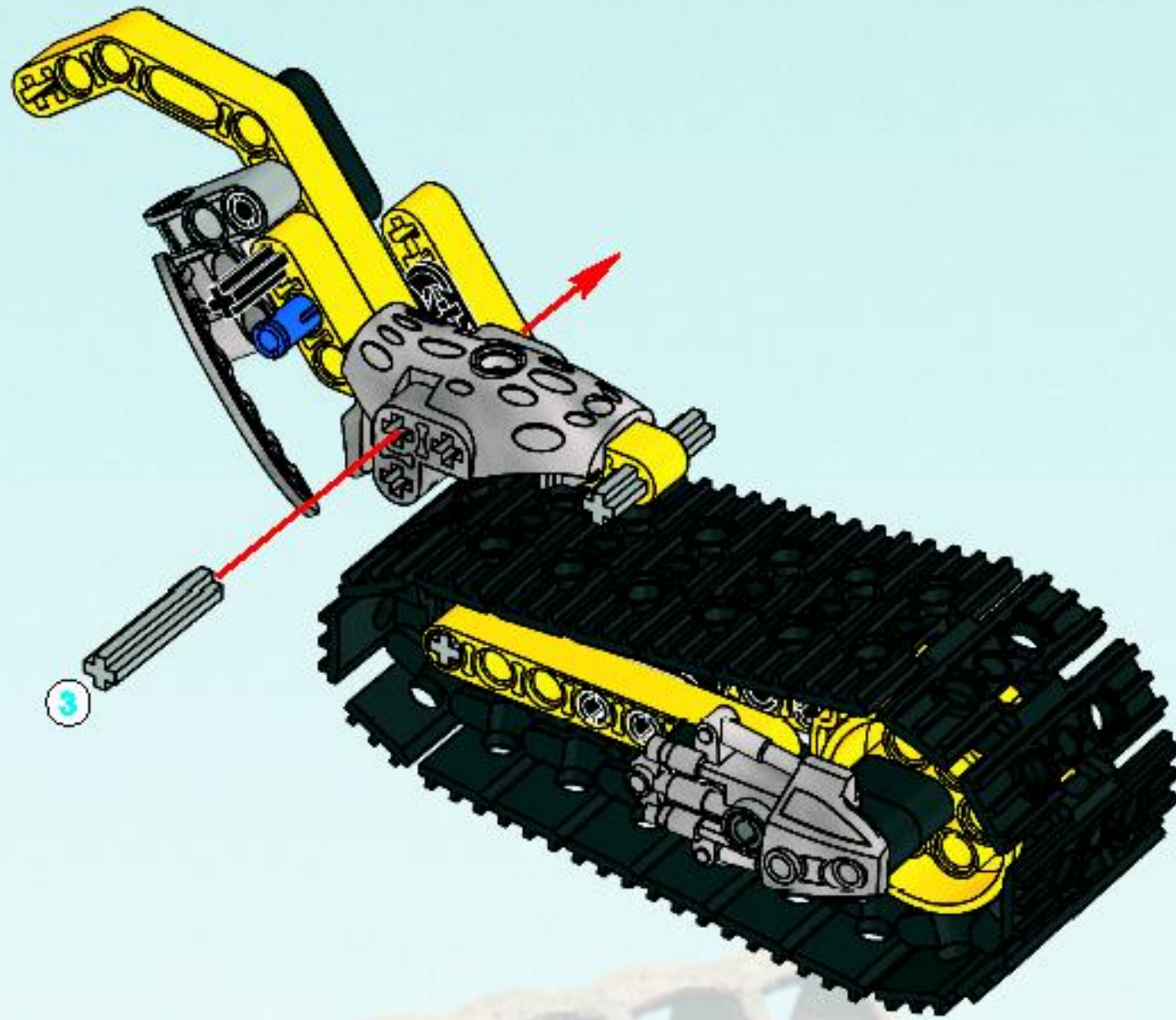



18

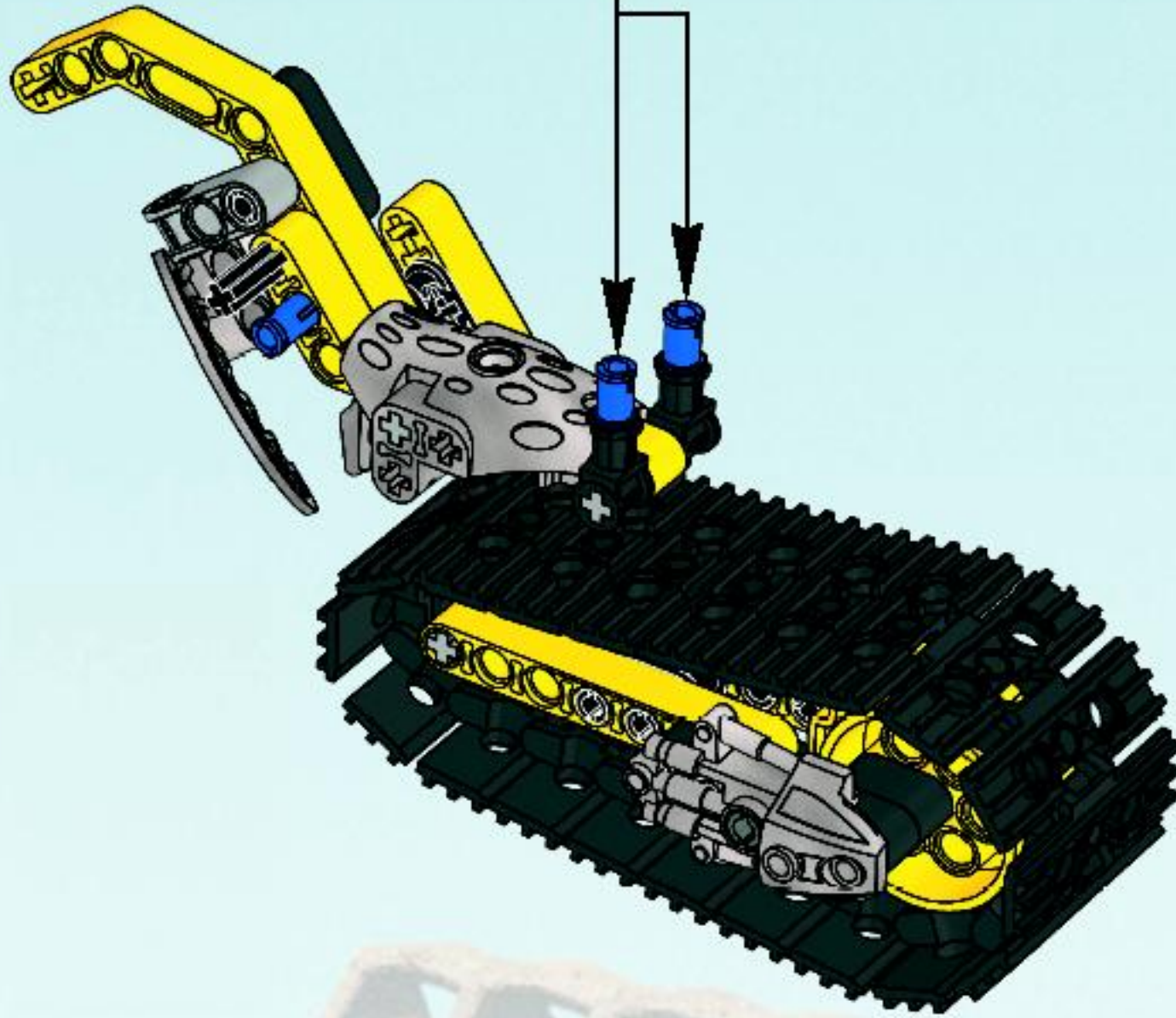



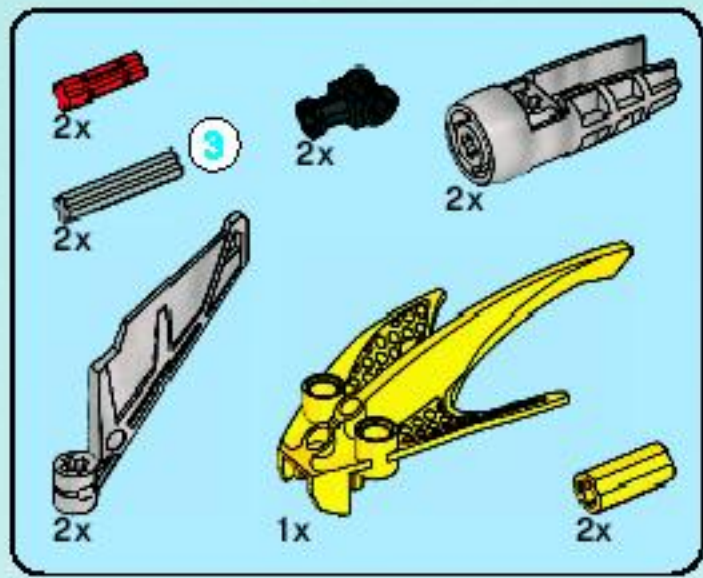

# 19

1

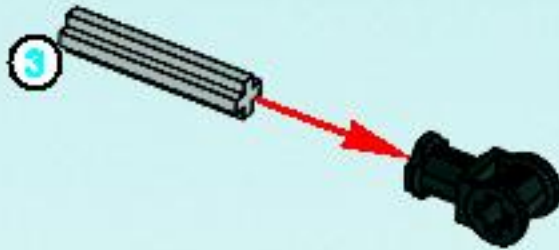

2

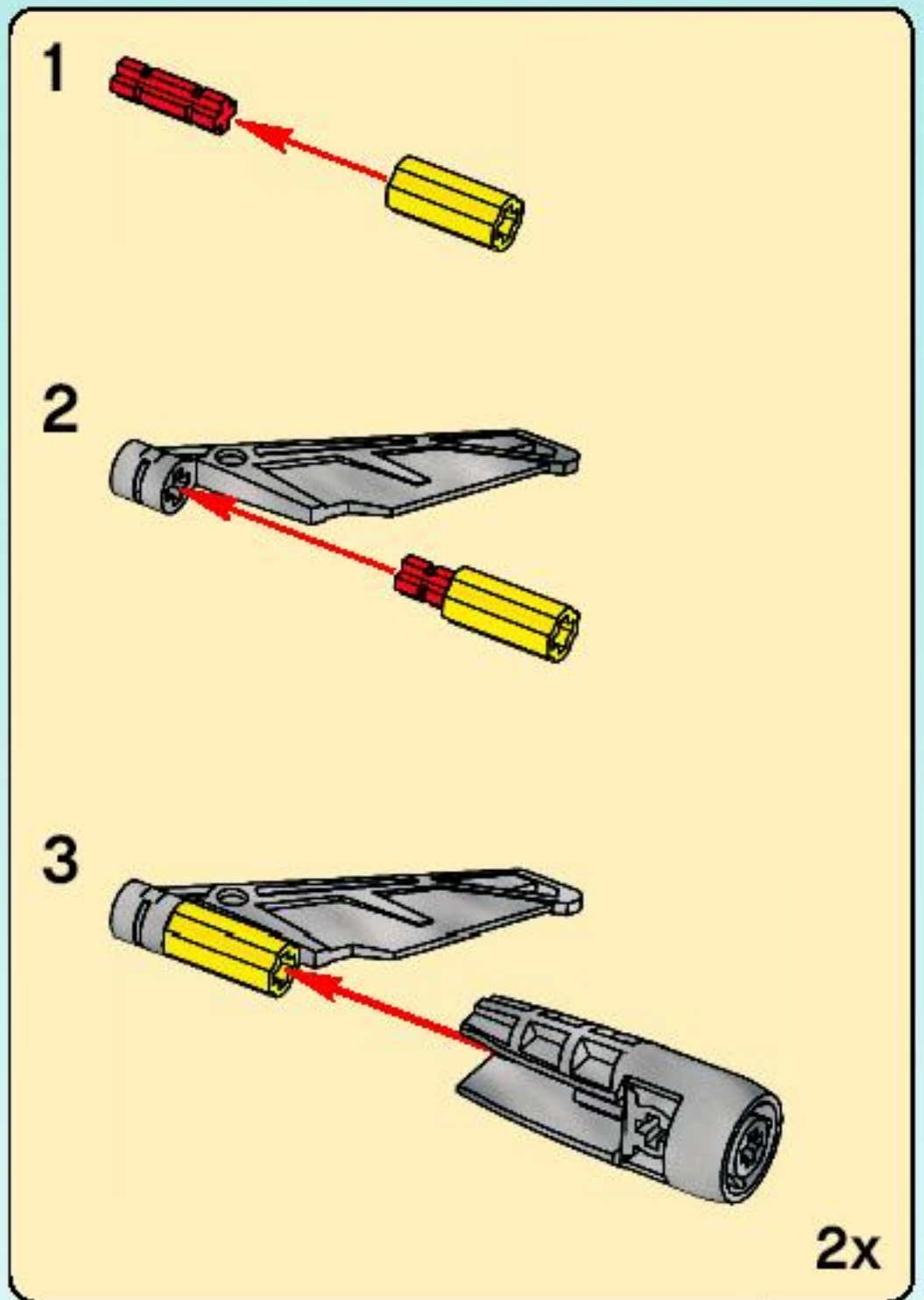

3

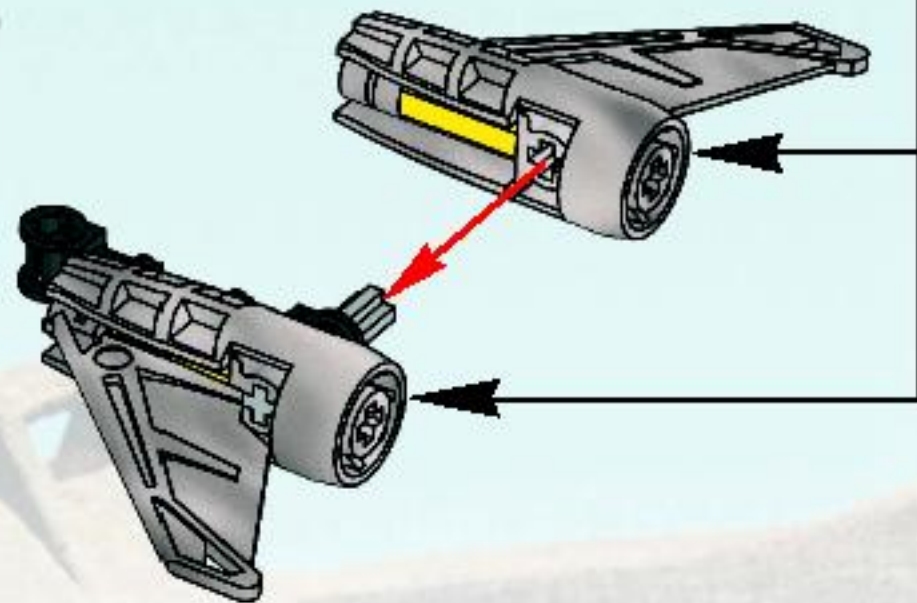

4

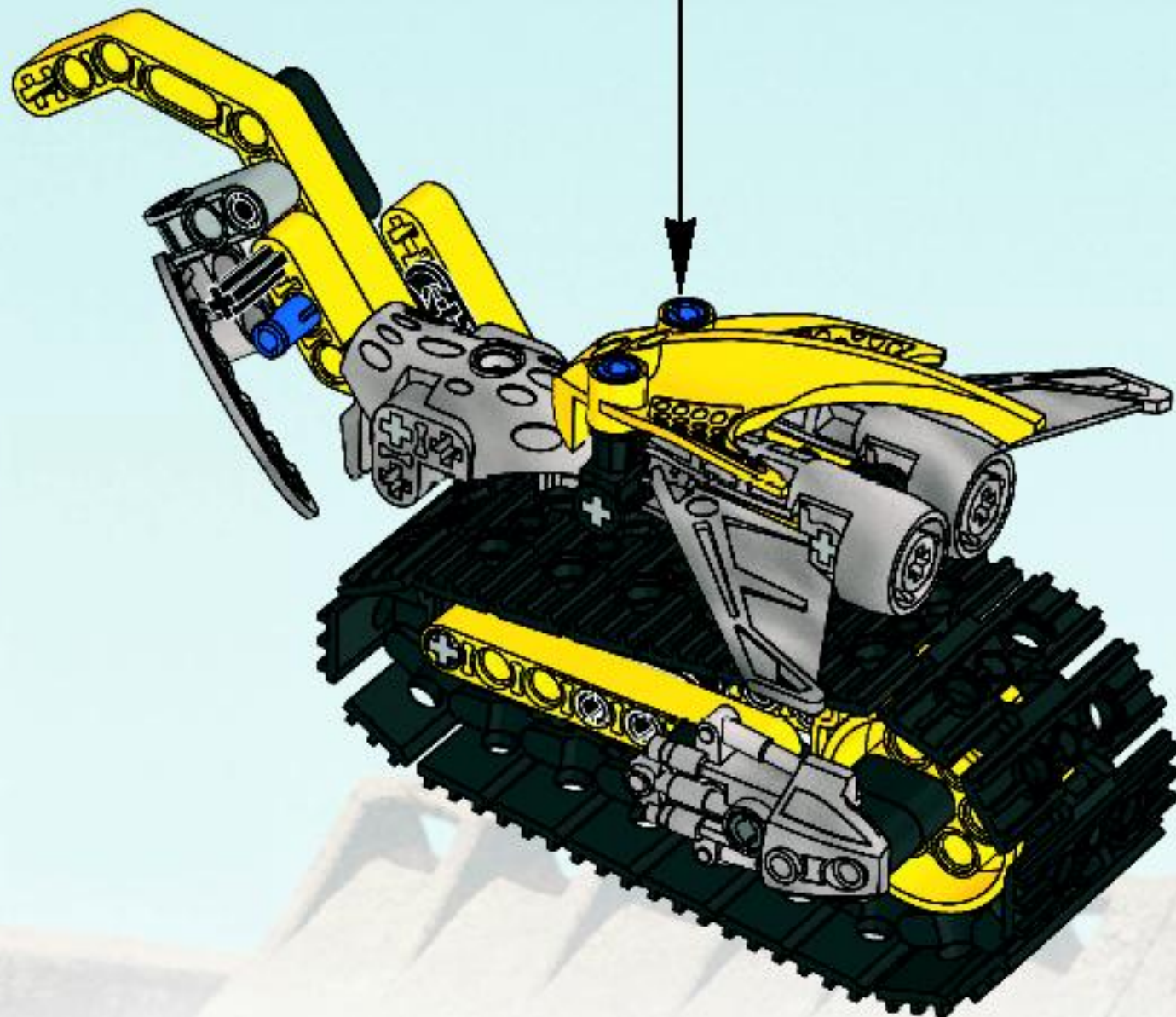
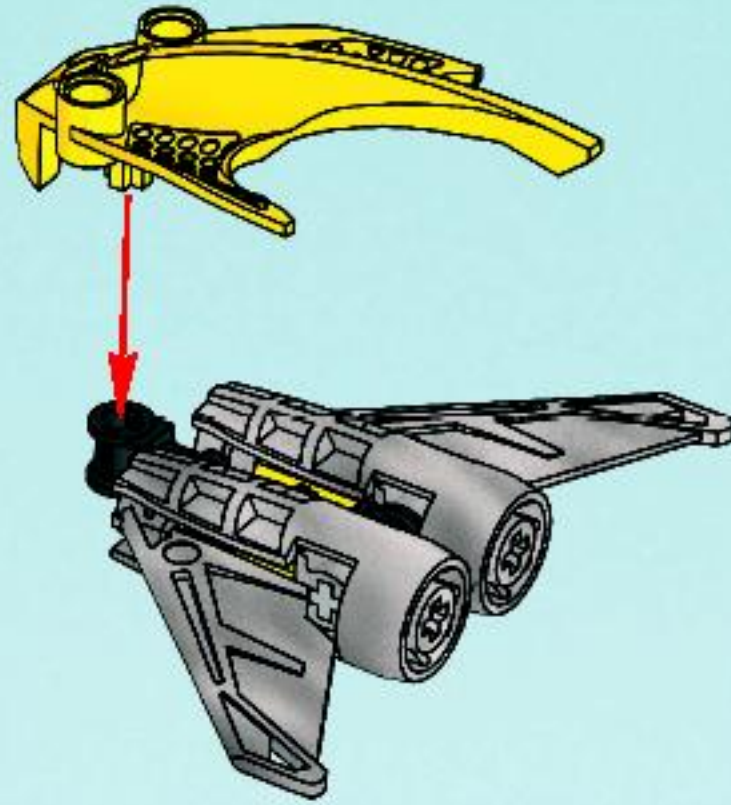



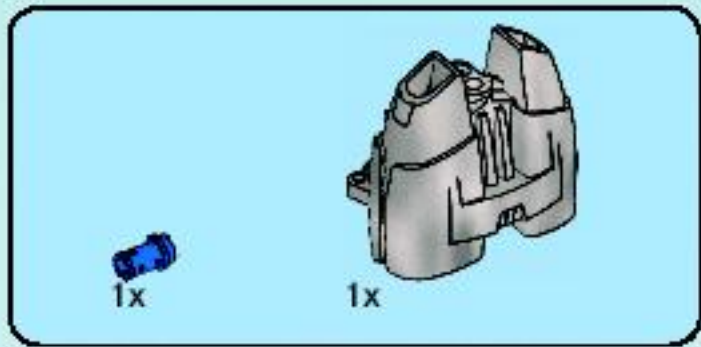
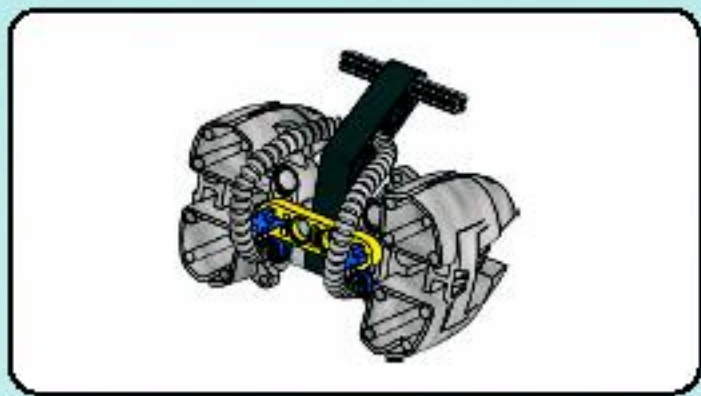

1

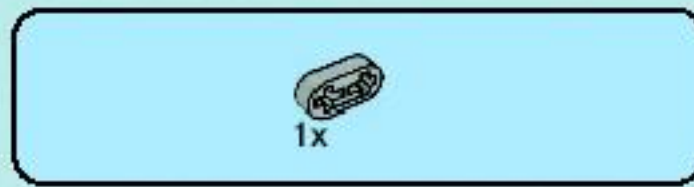
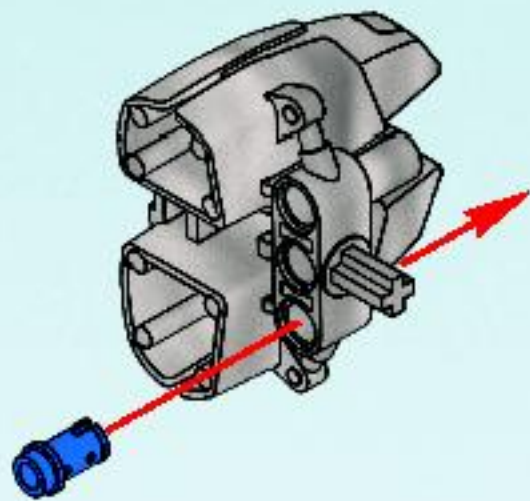

2

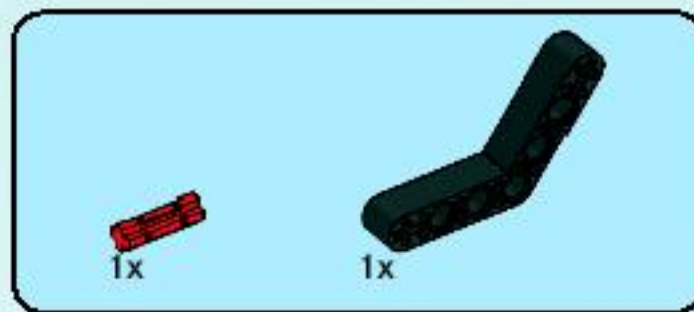
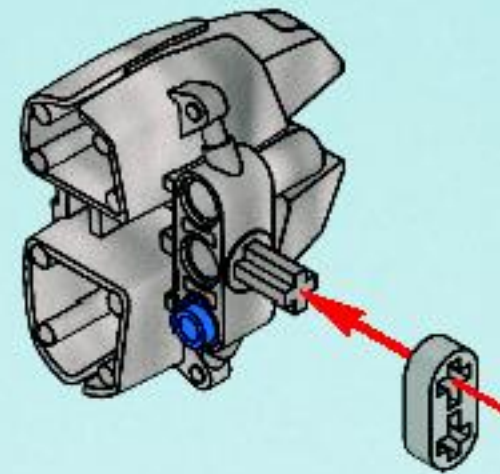

3

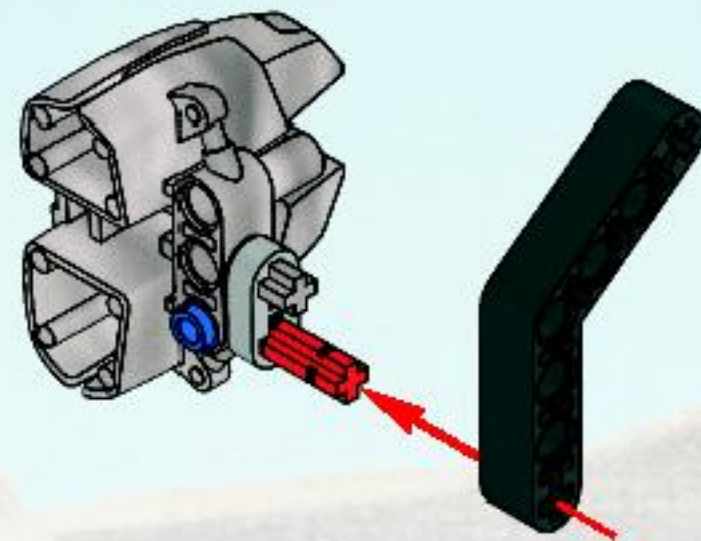

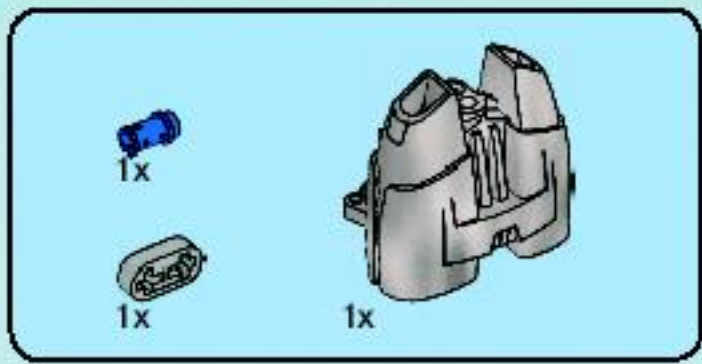

4

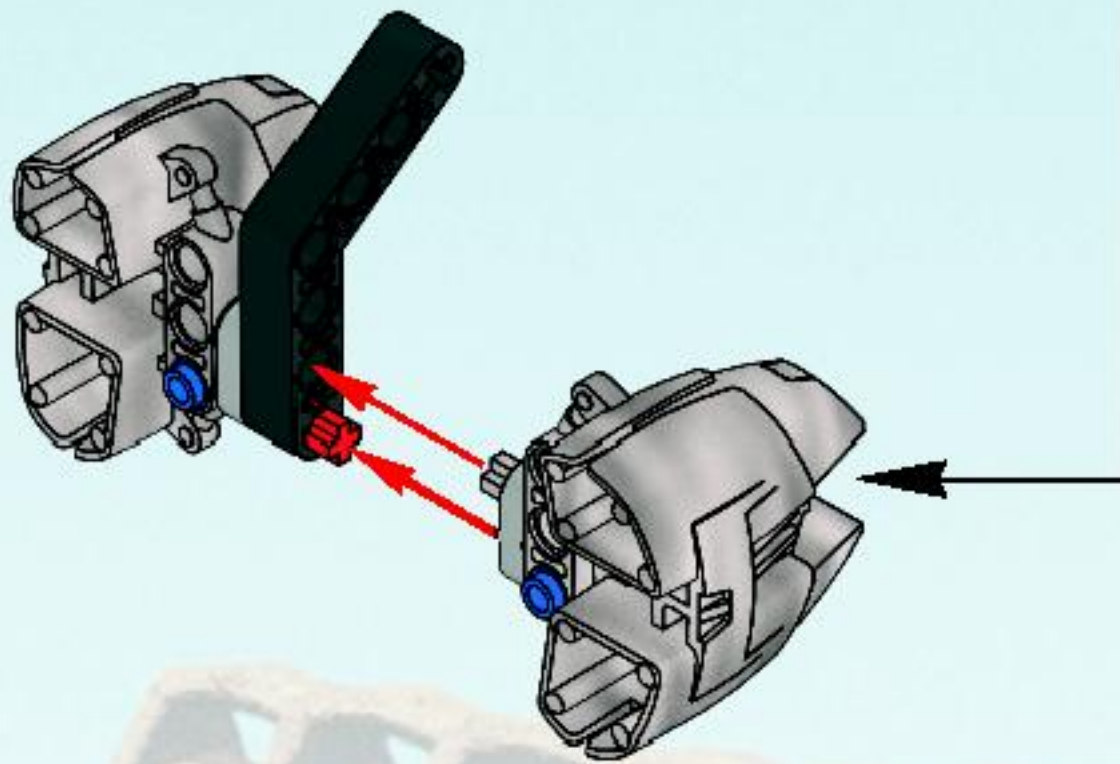
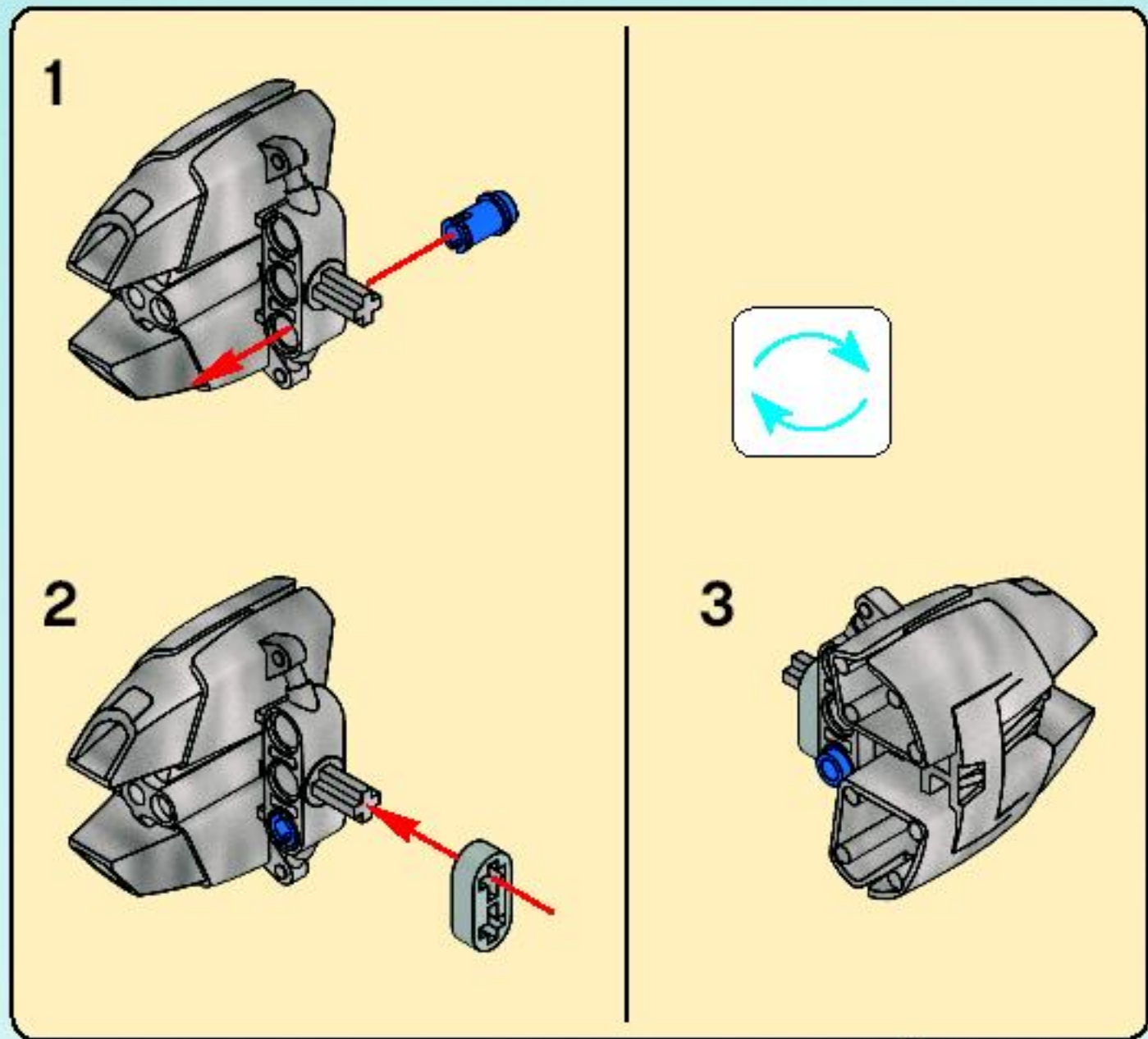





5

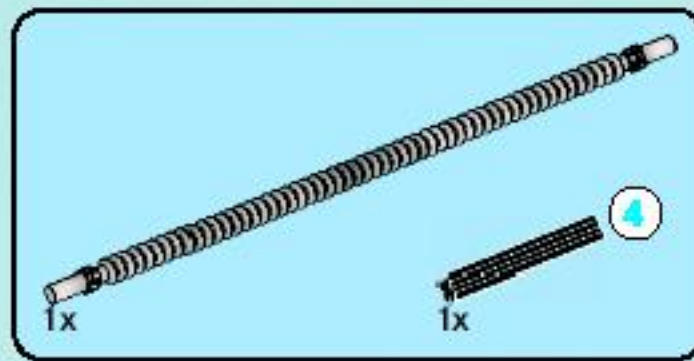
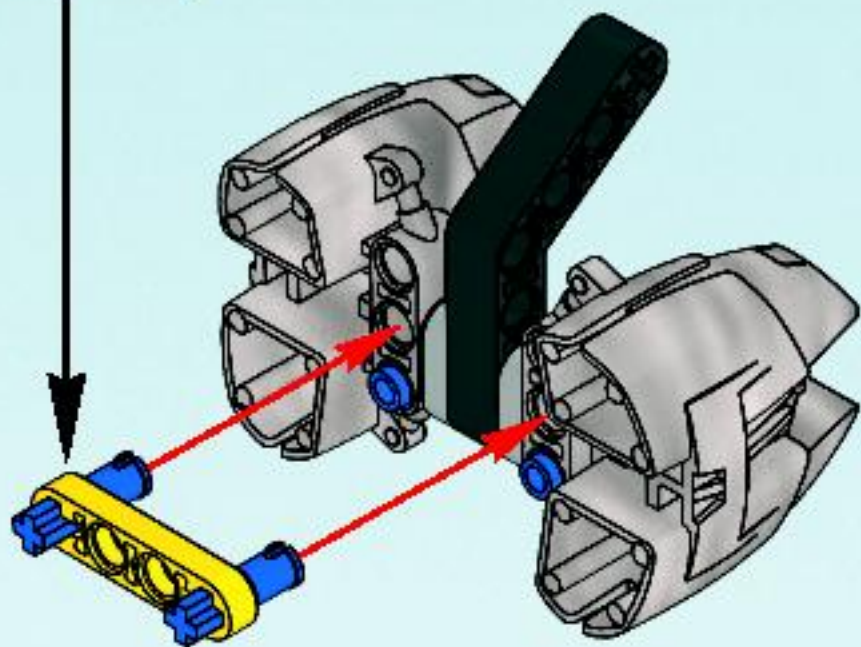
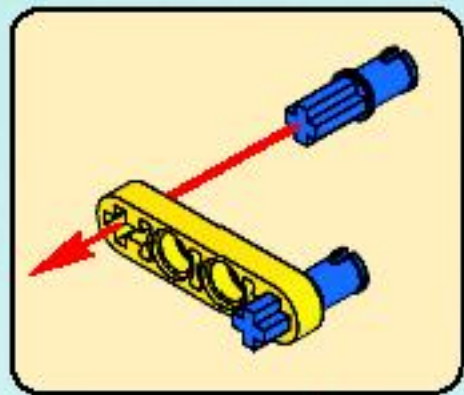

6

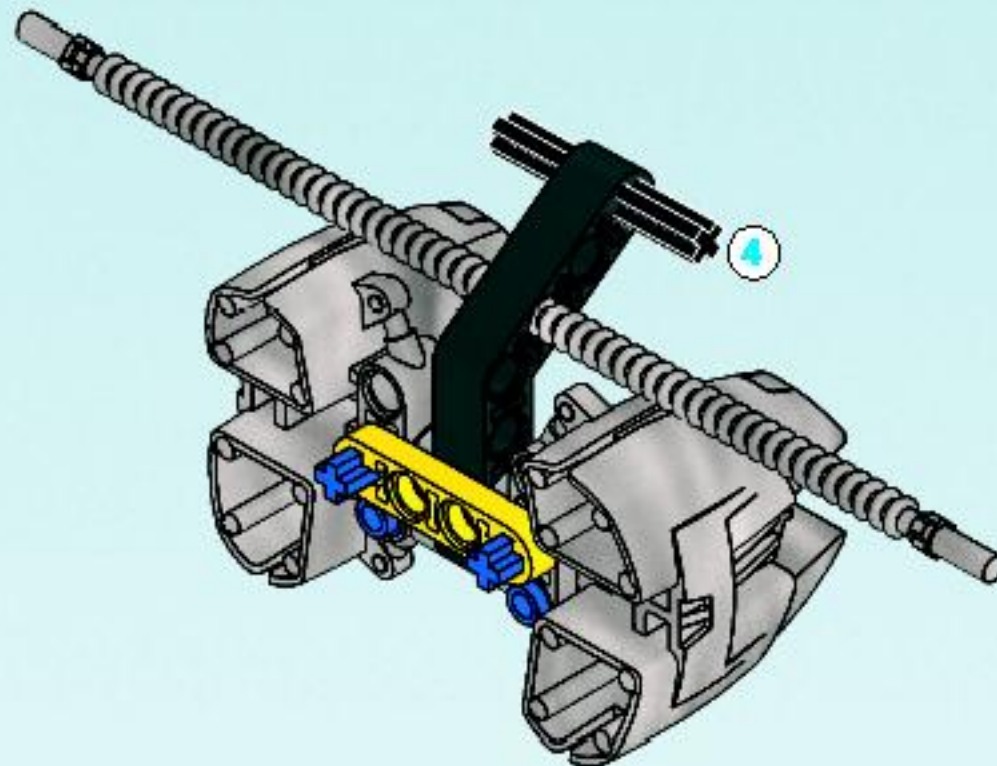



7

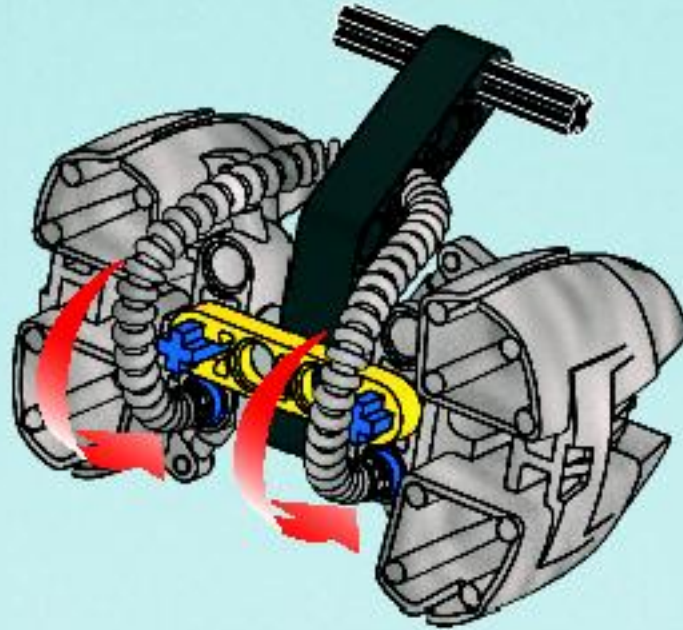

8

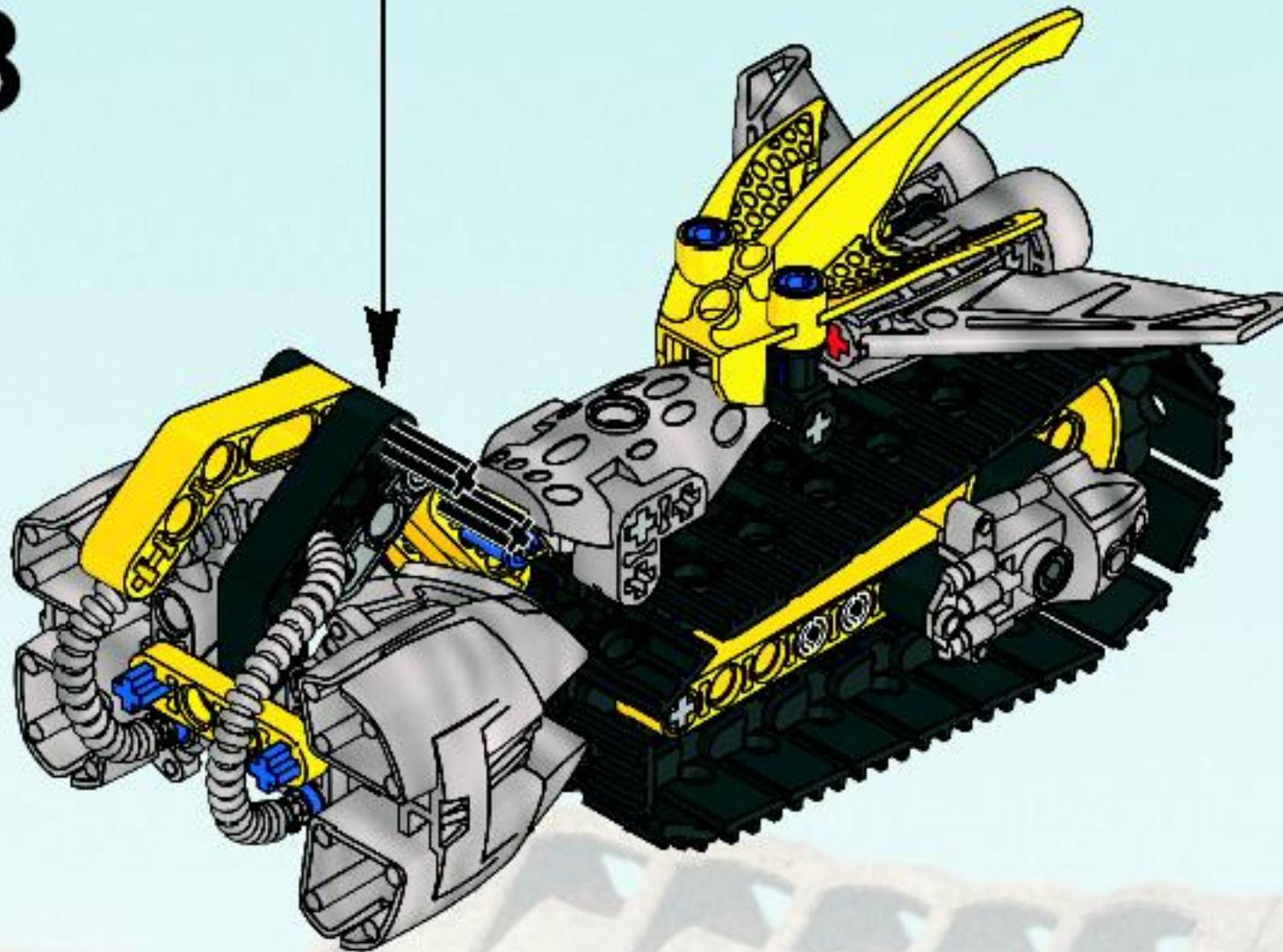



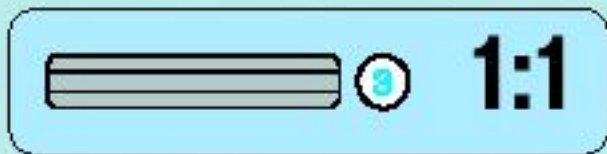

9

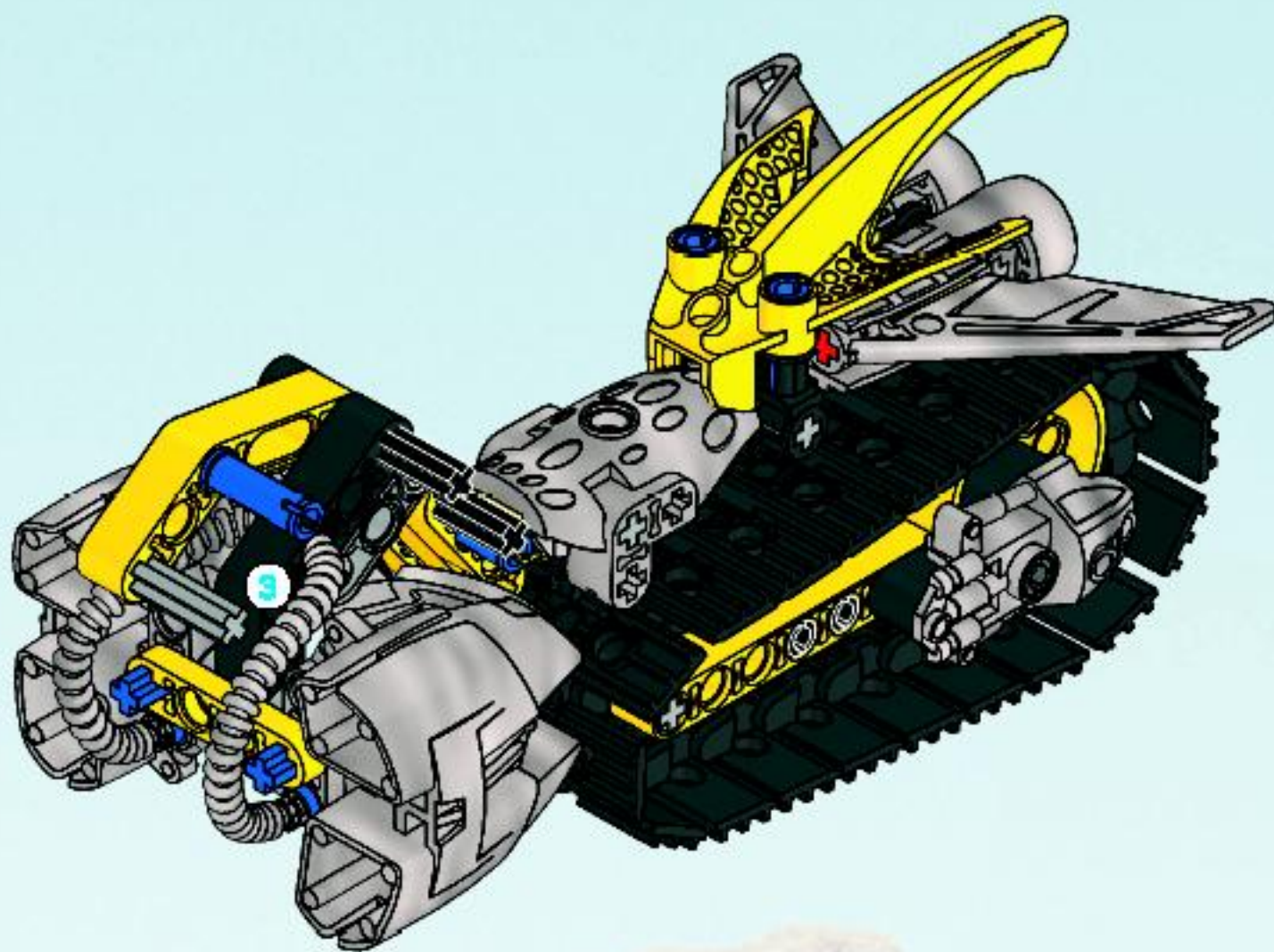



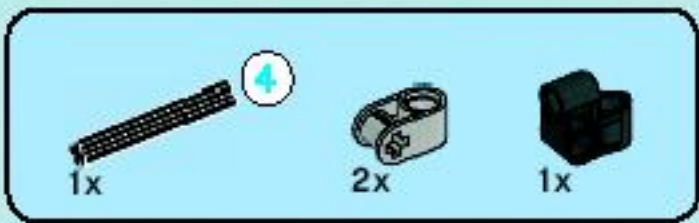

# 10

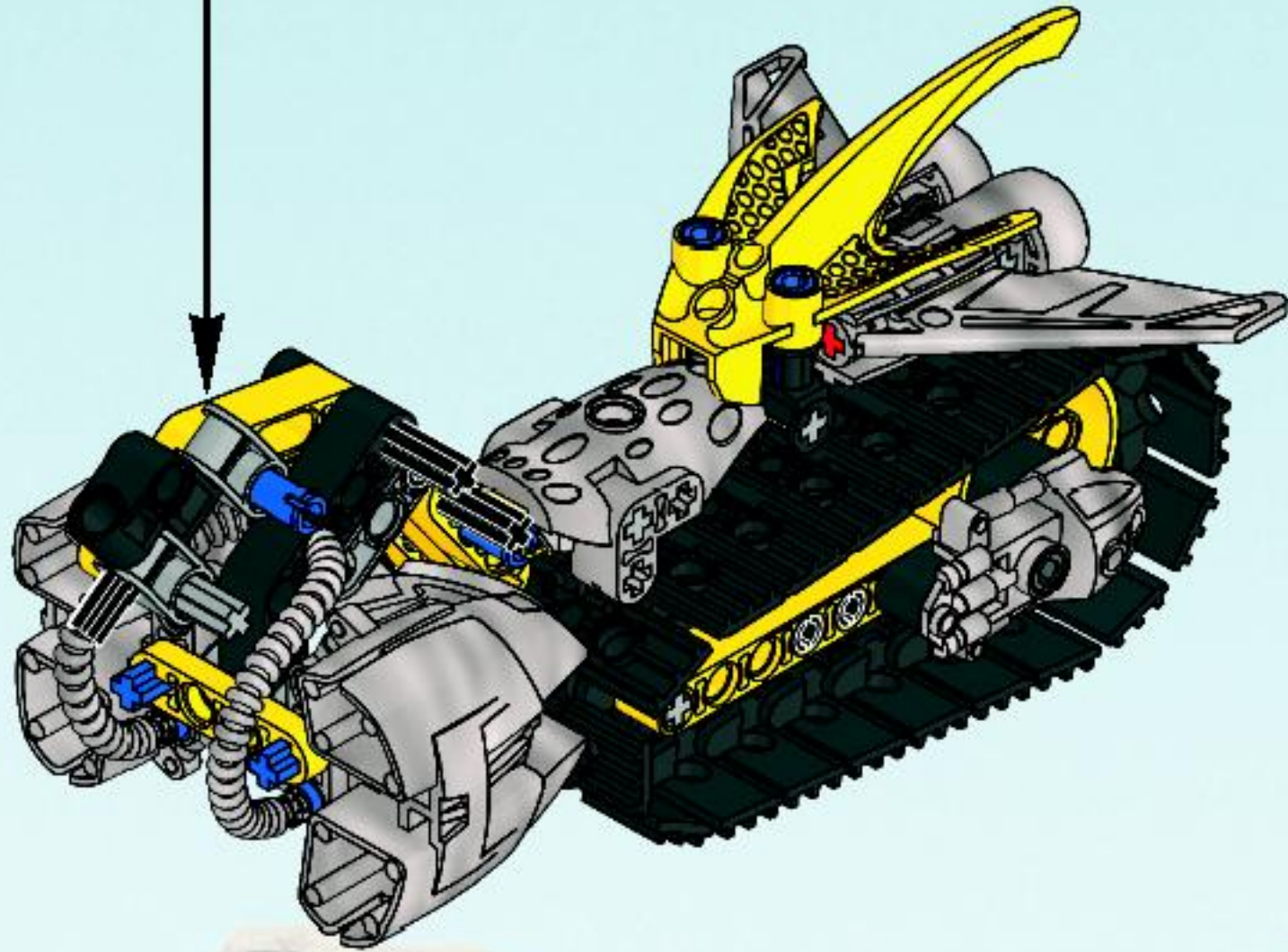
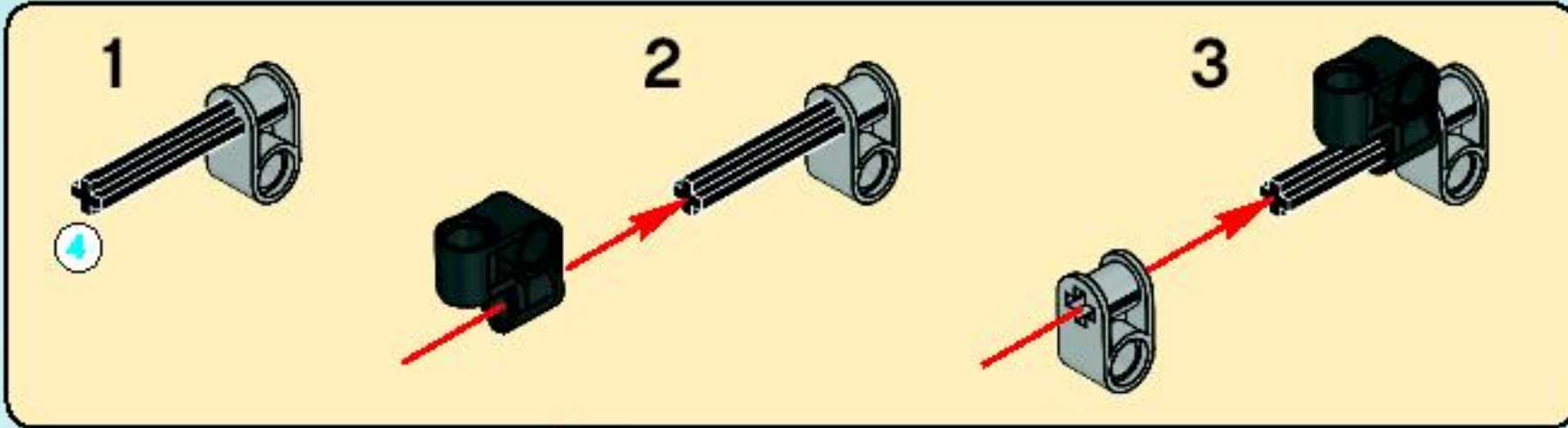



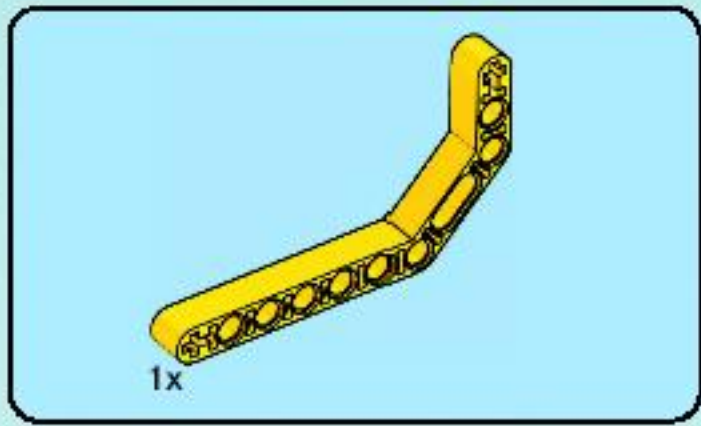

11

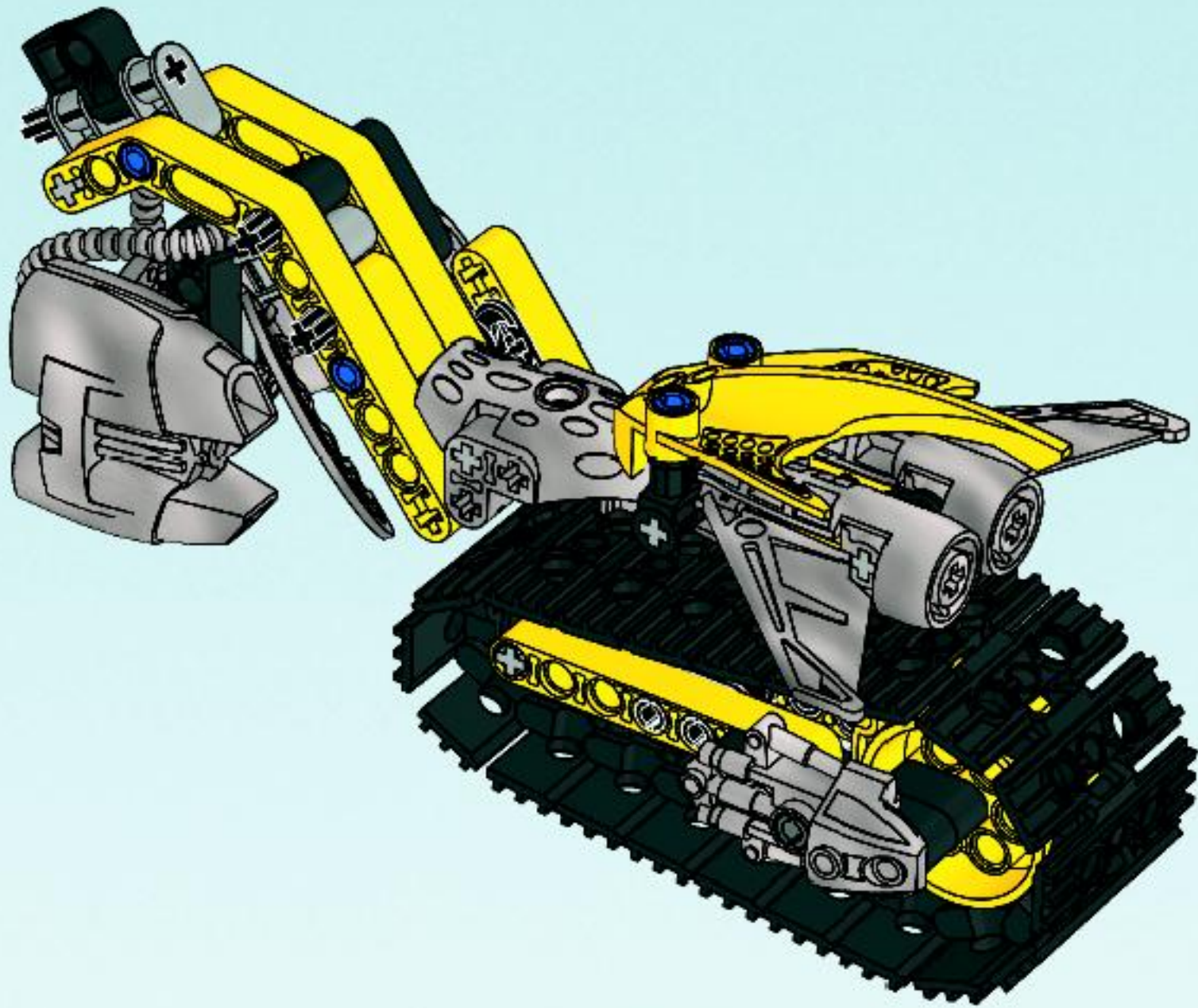





12

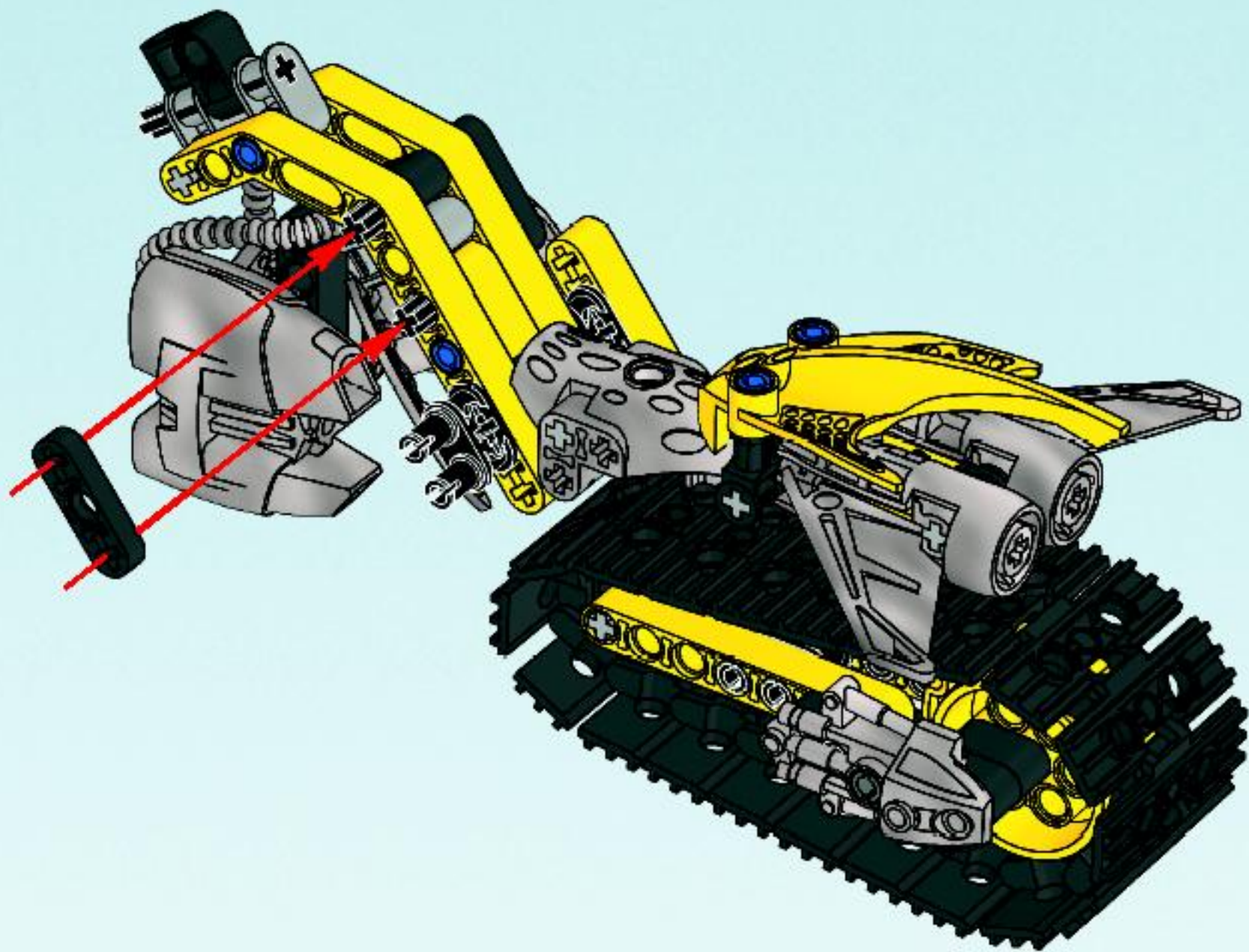



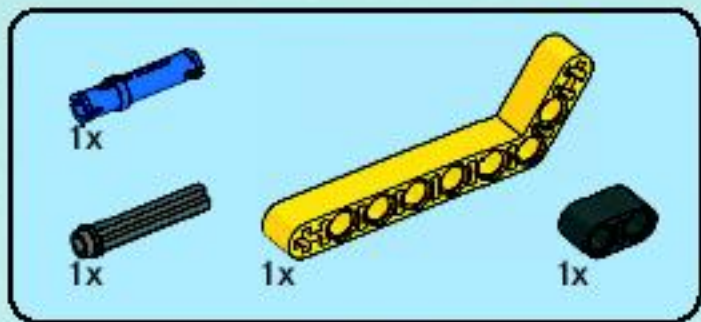

# 13

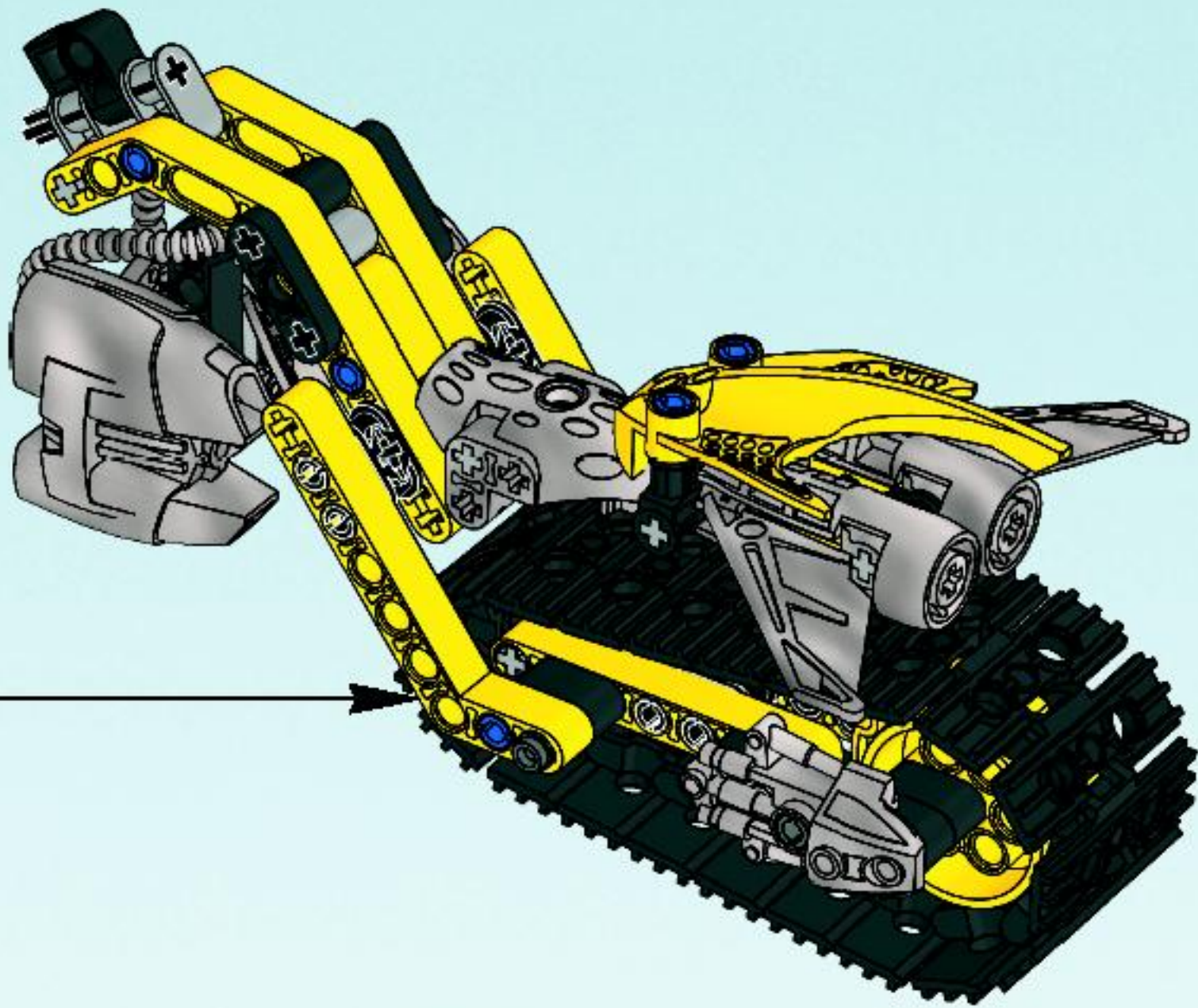
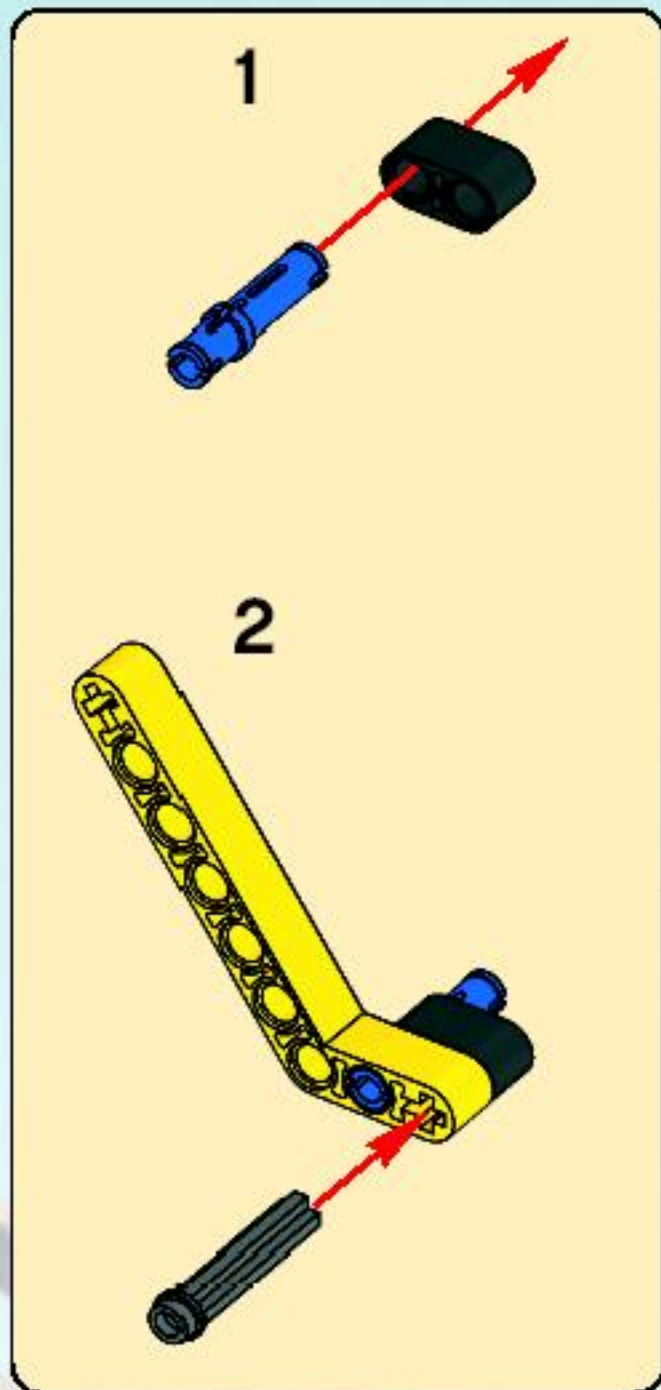



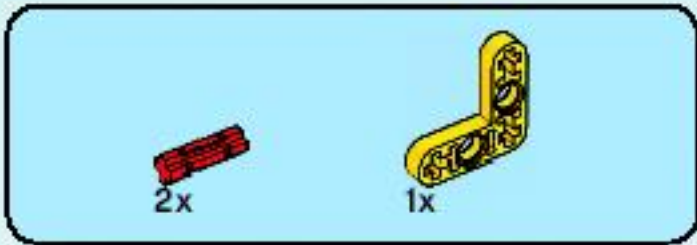
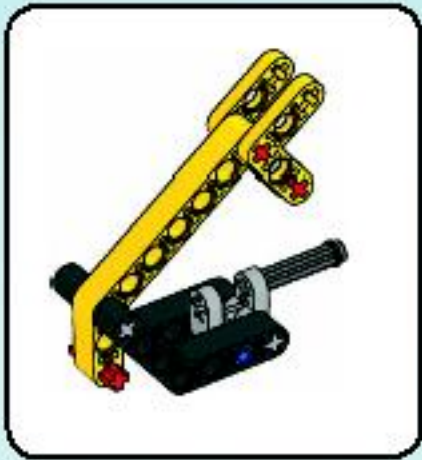

1

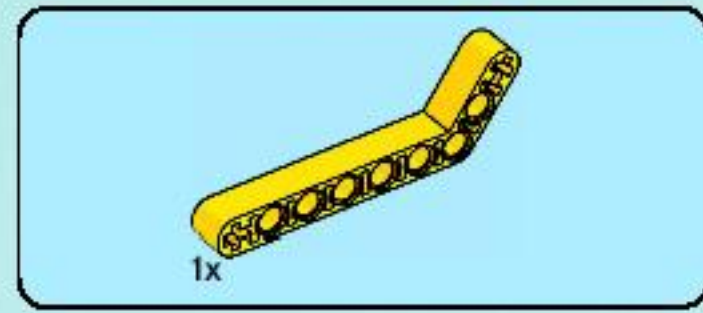
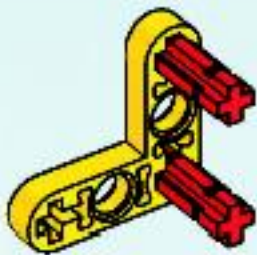

2

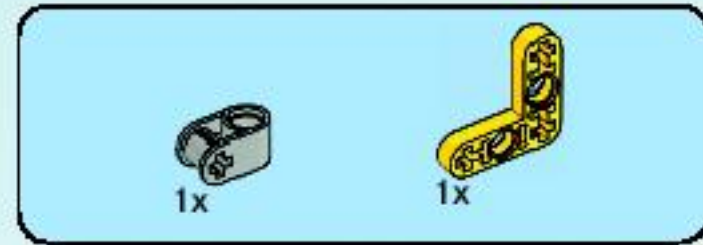
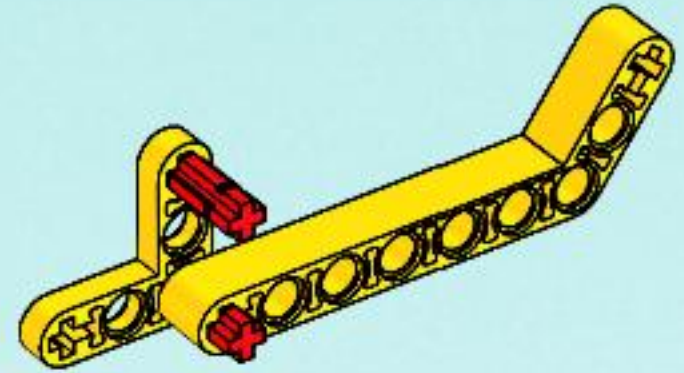

3

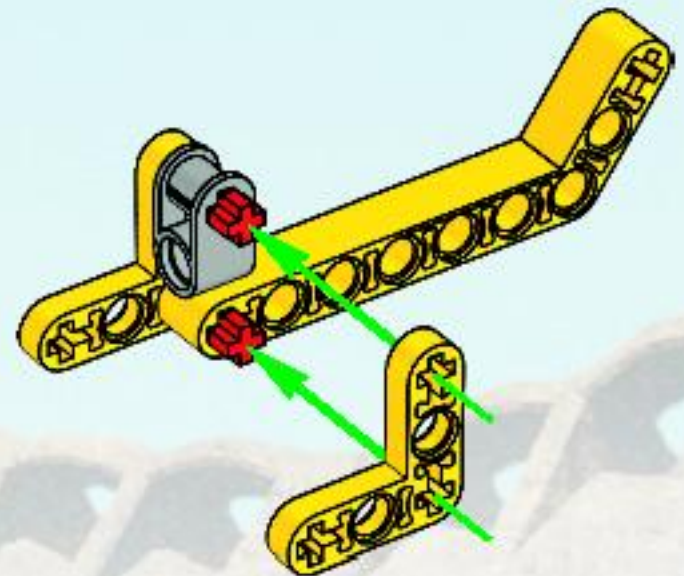



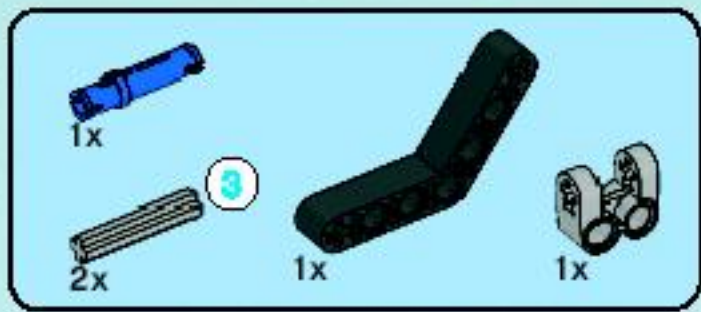

4

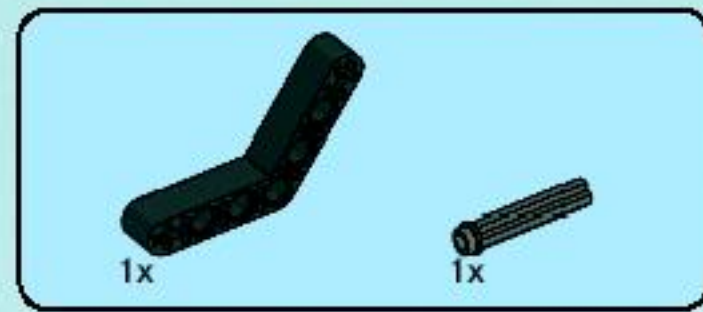
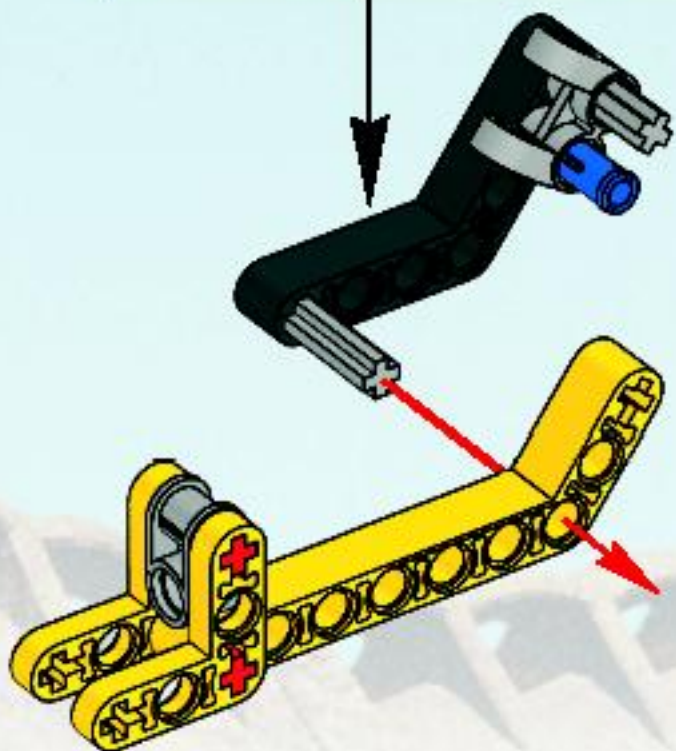
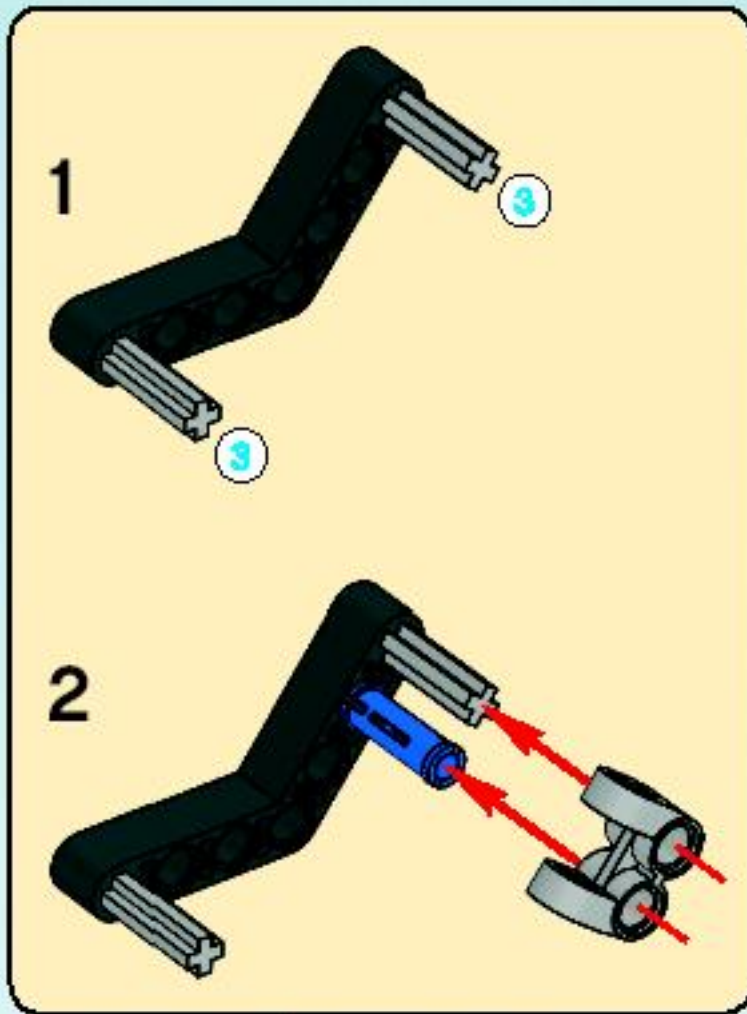

5

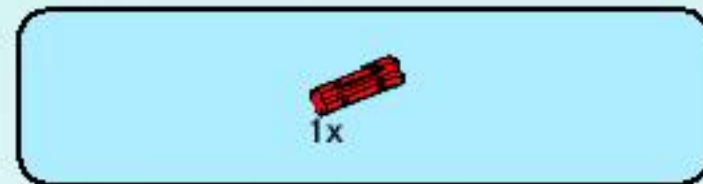
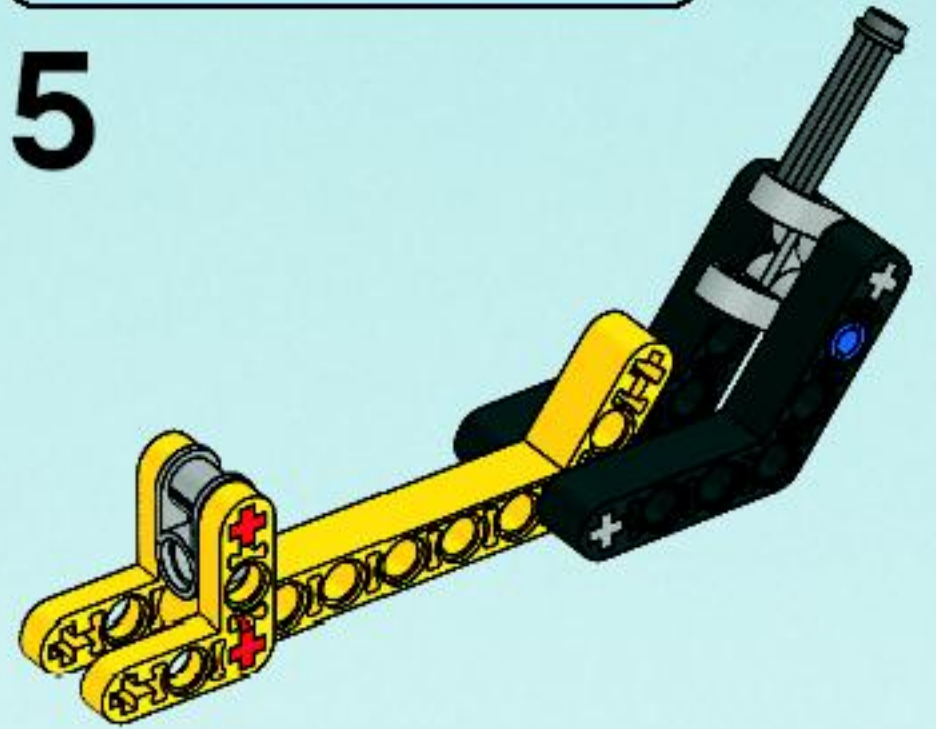

6

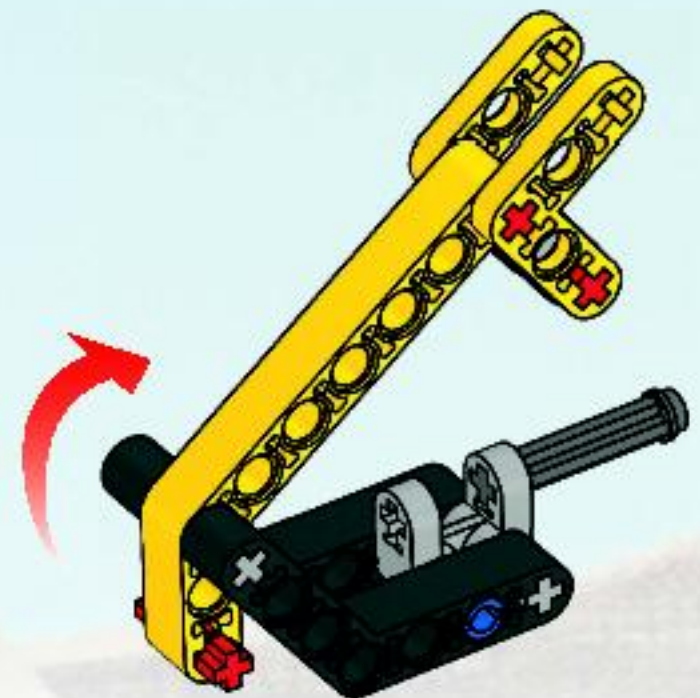

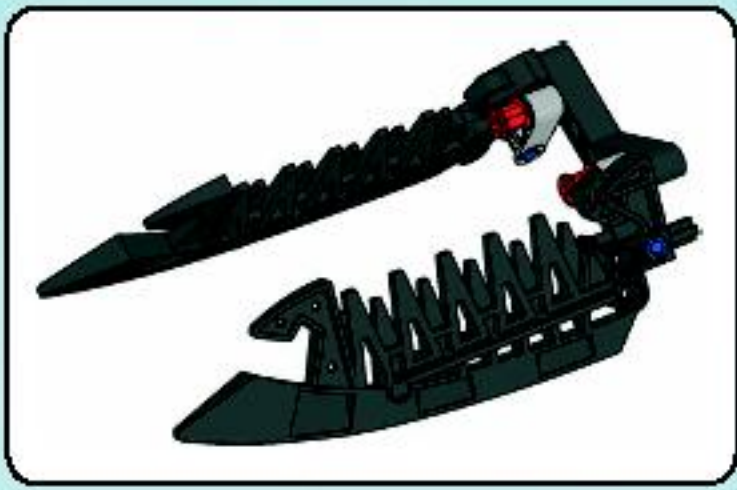

1

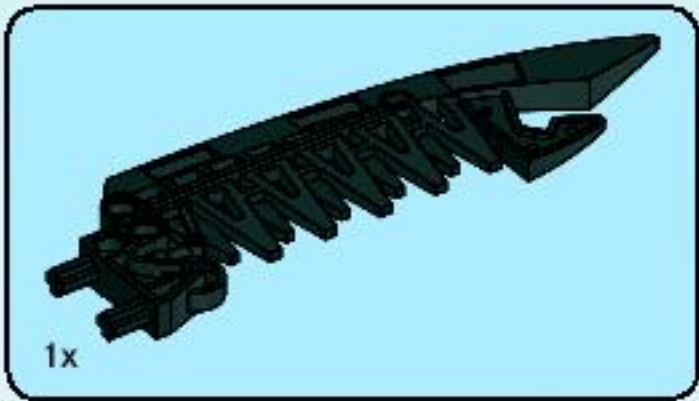
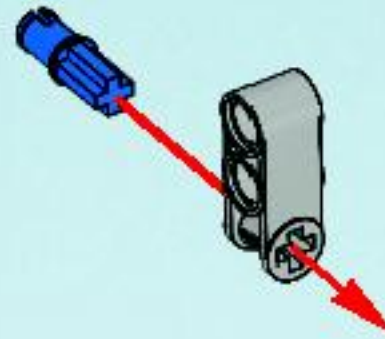

2







3

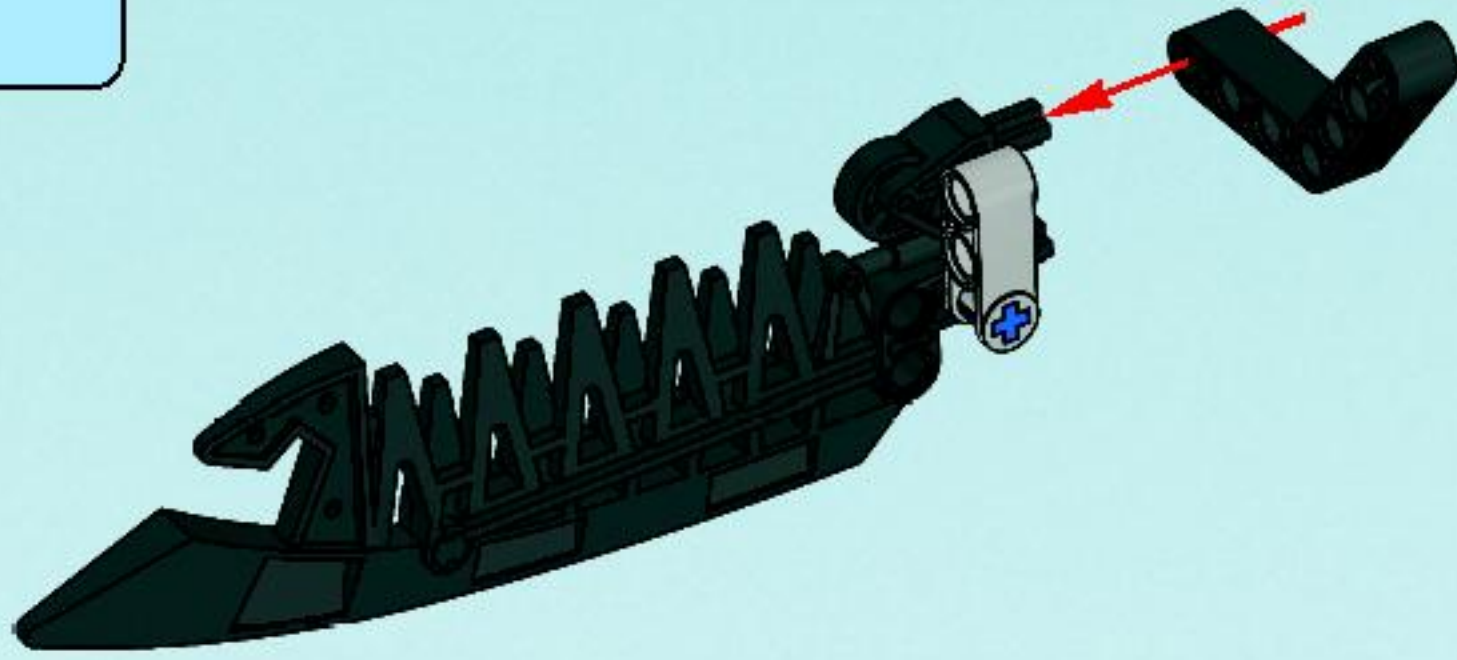

4



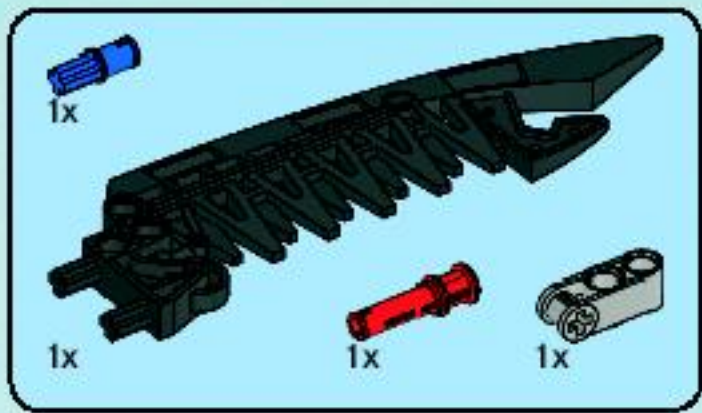

5

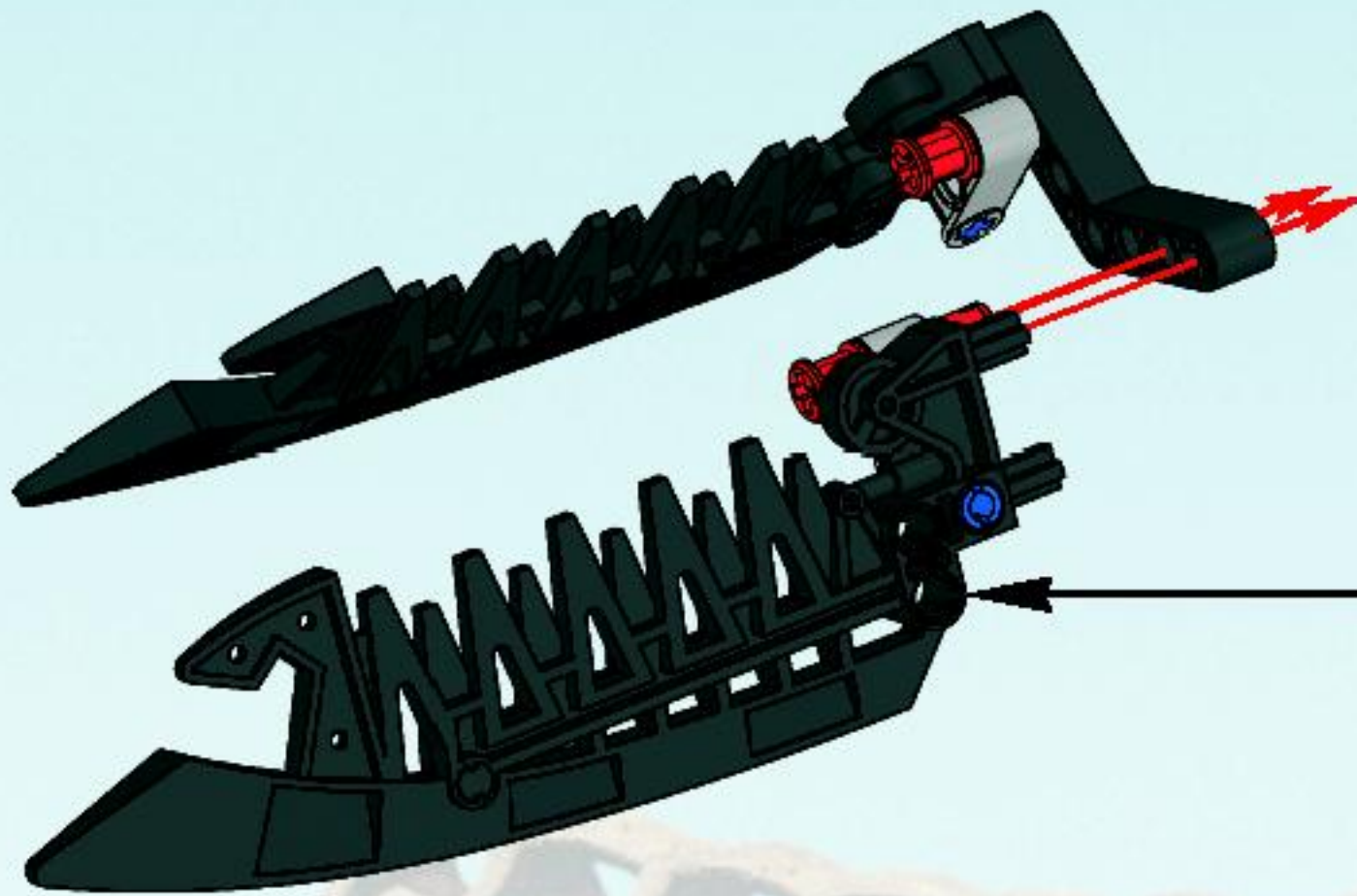
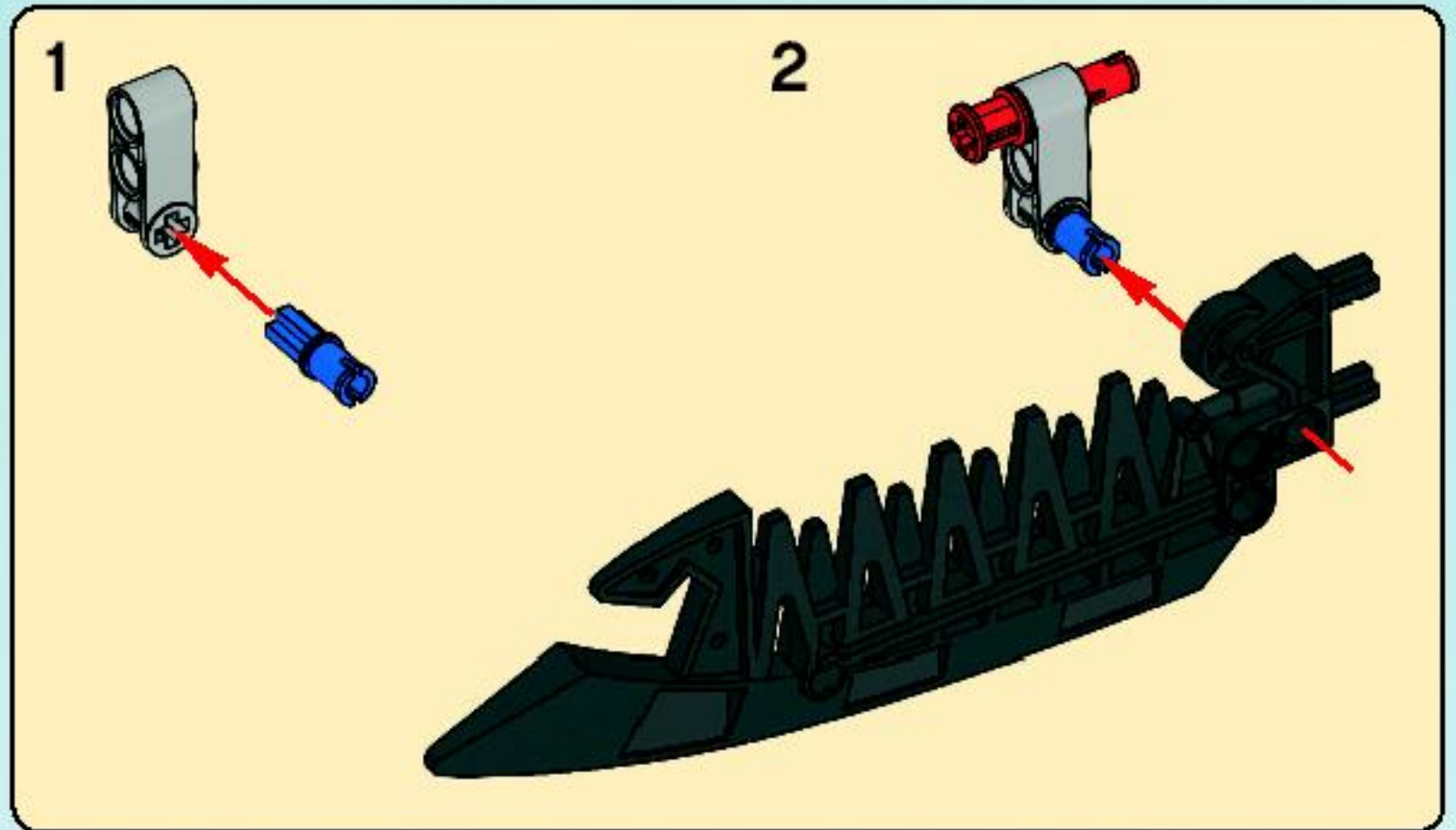



6



7

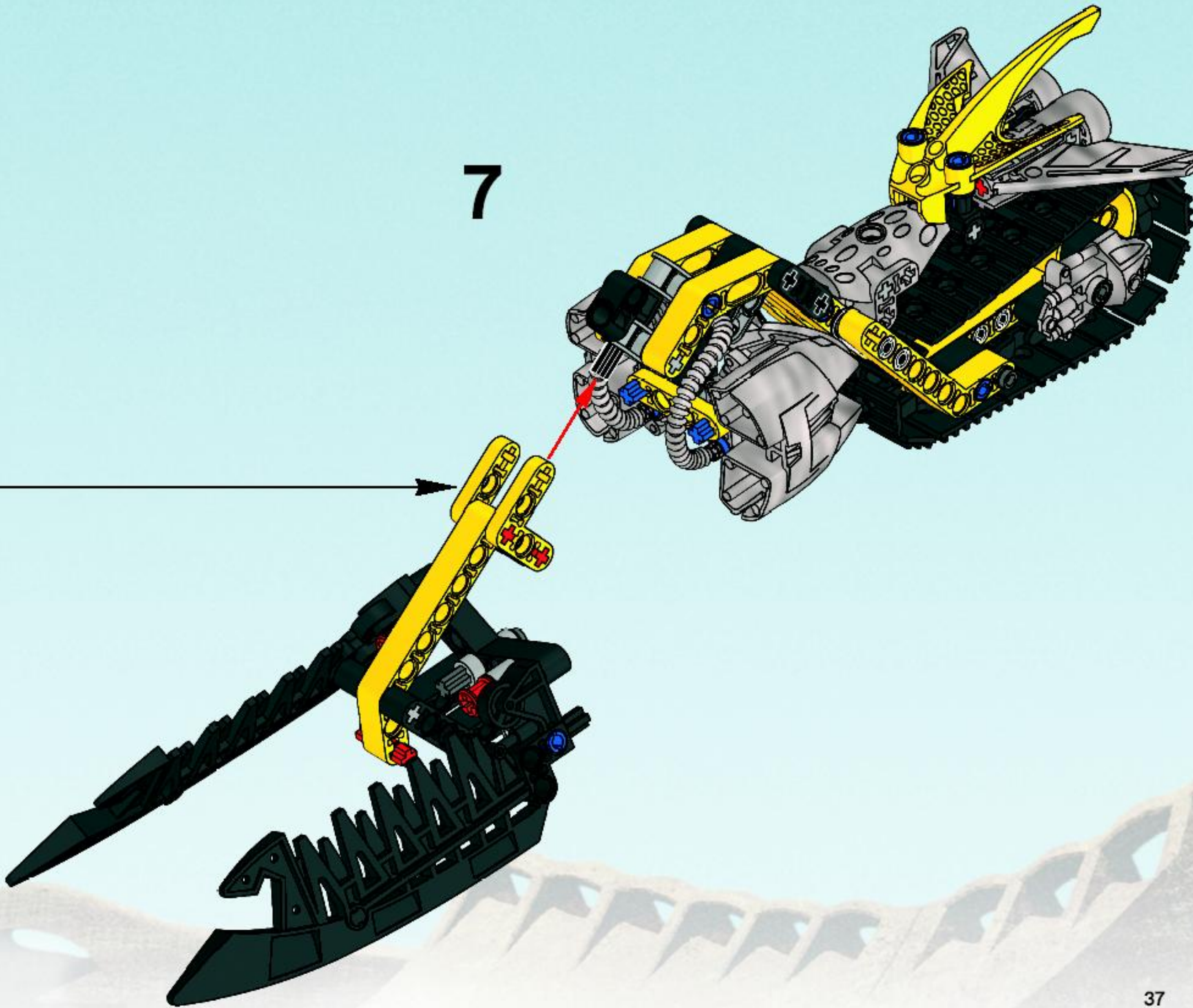



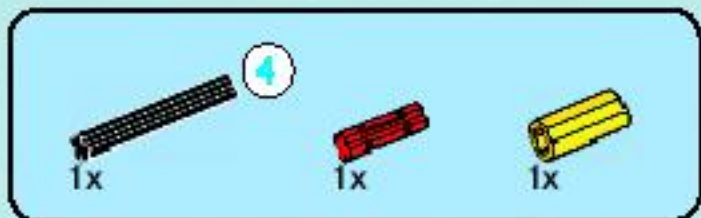

8

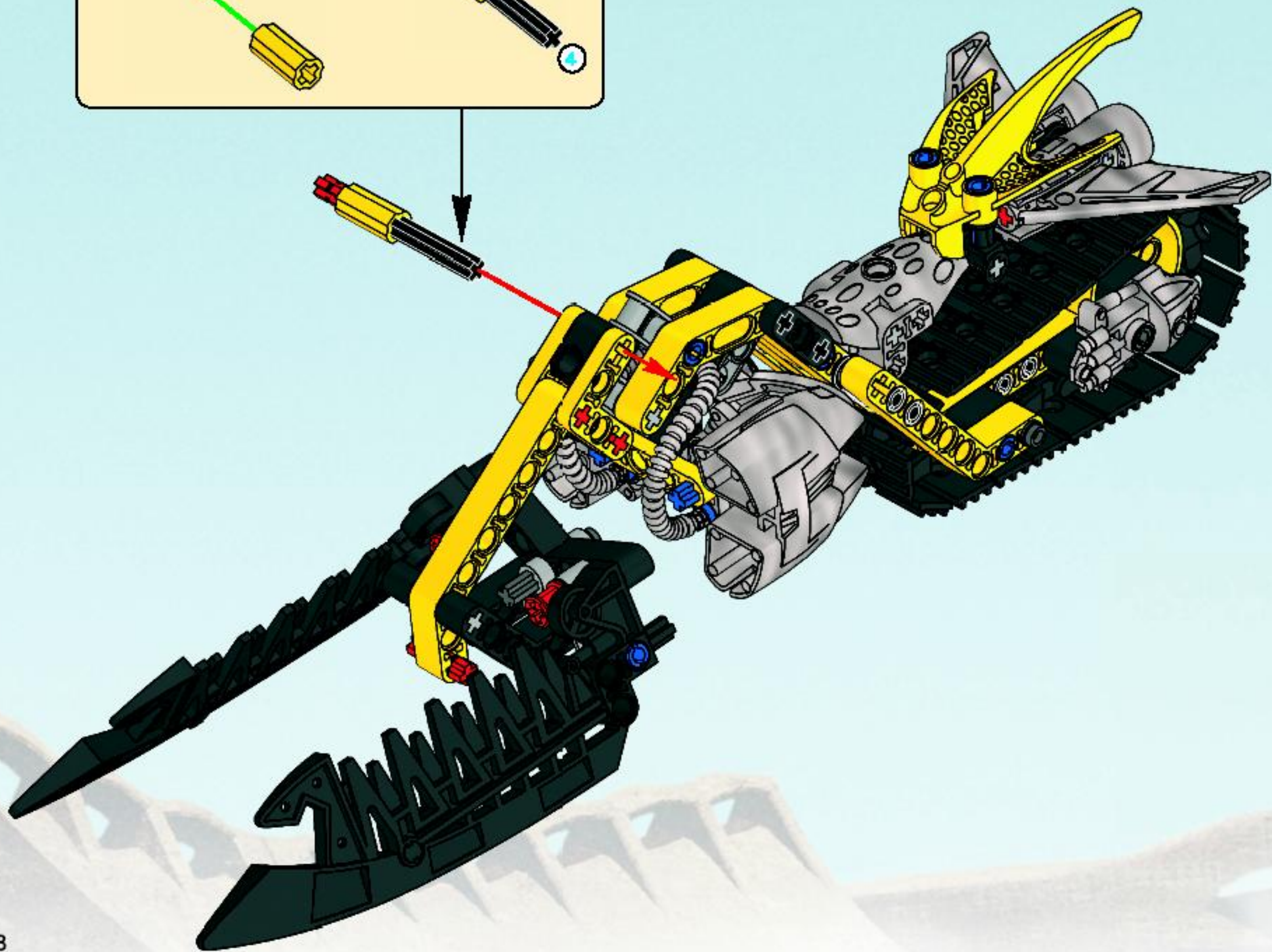
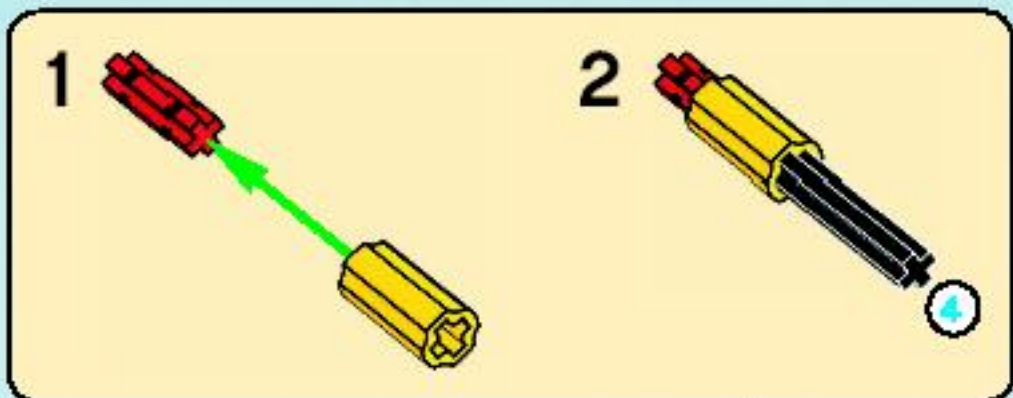





9

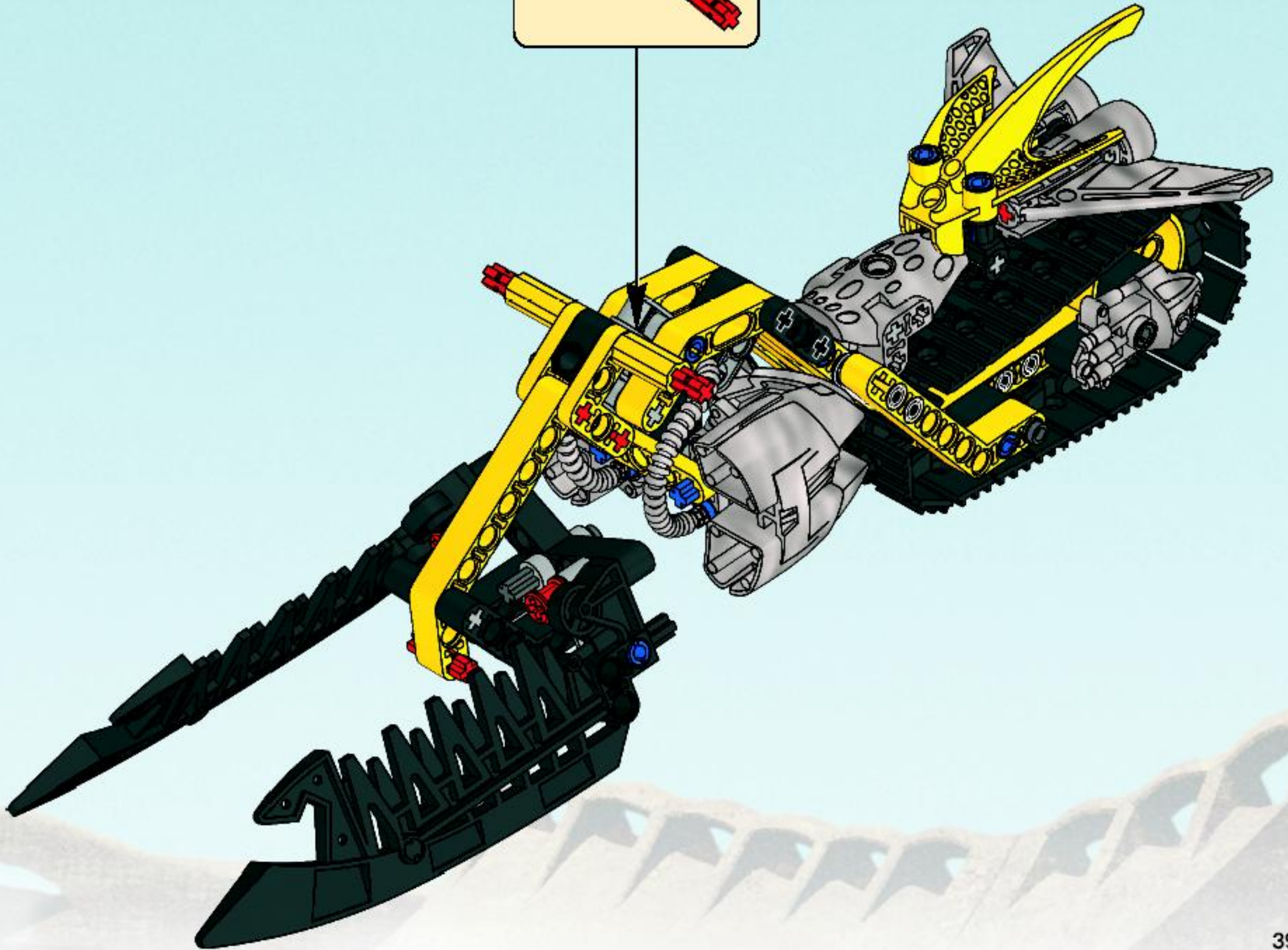
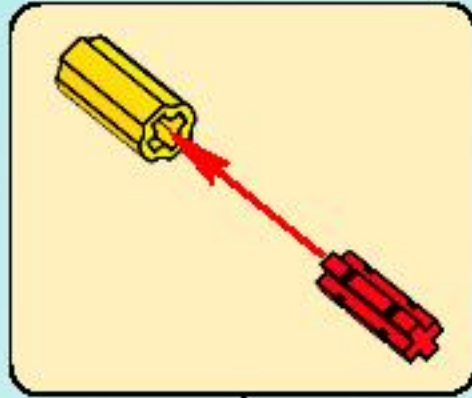



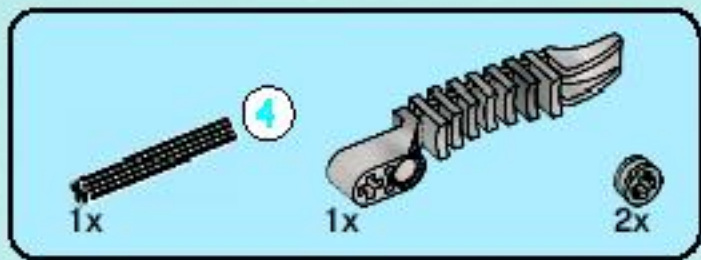

10

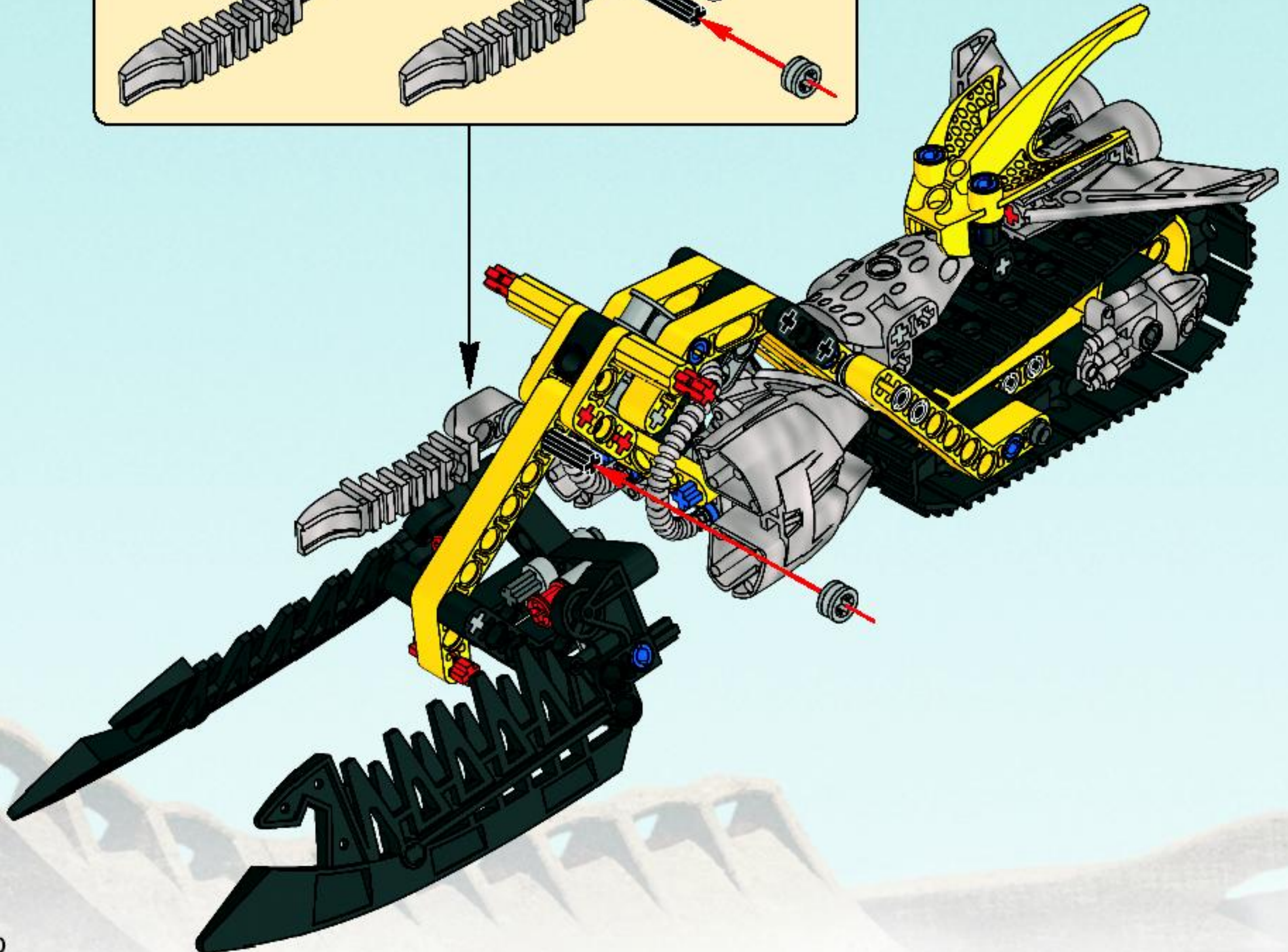
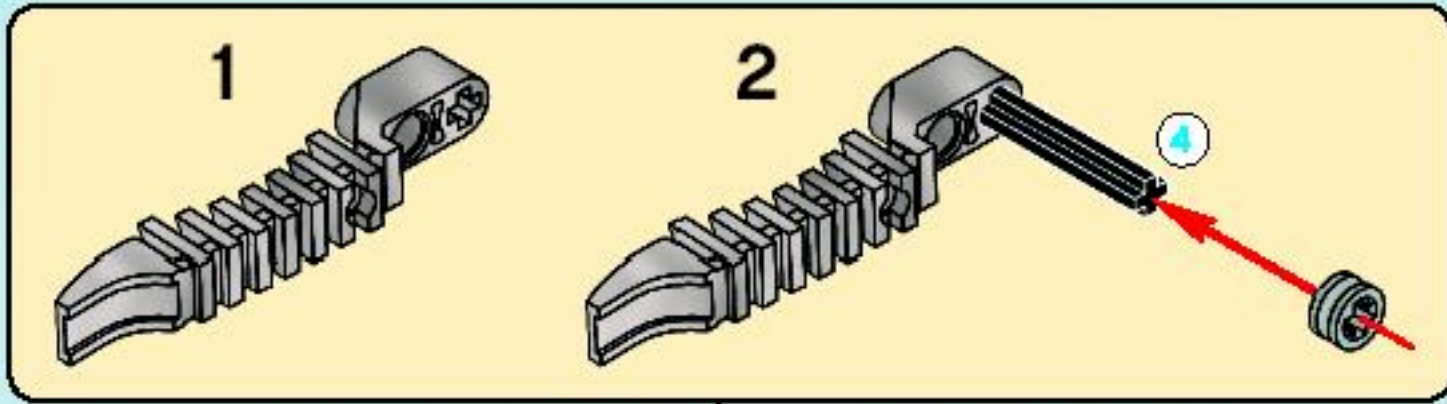



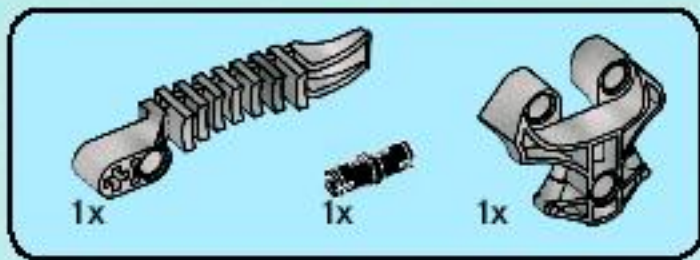

11

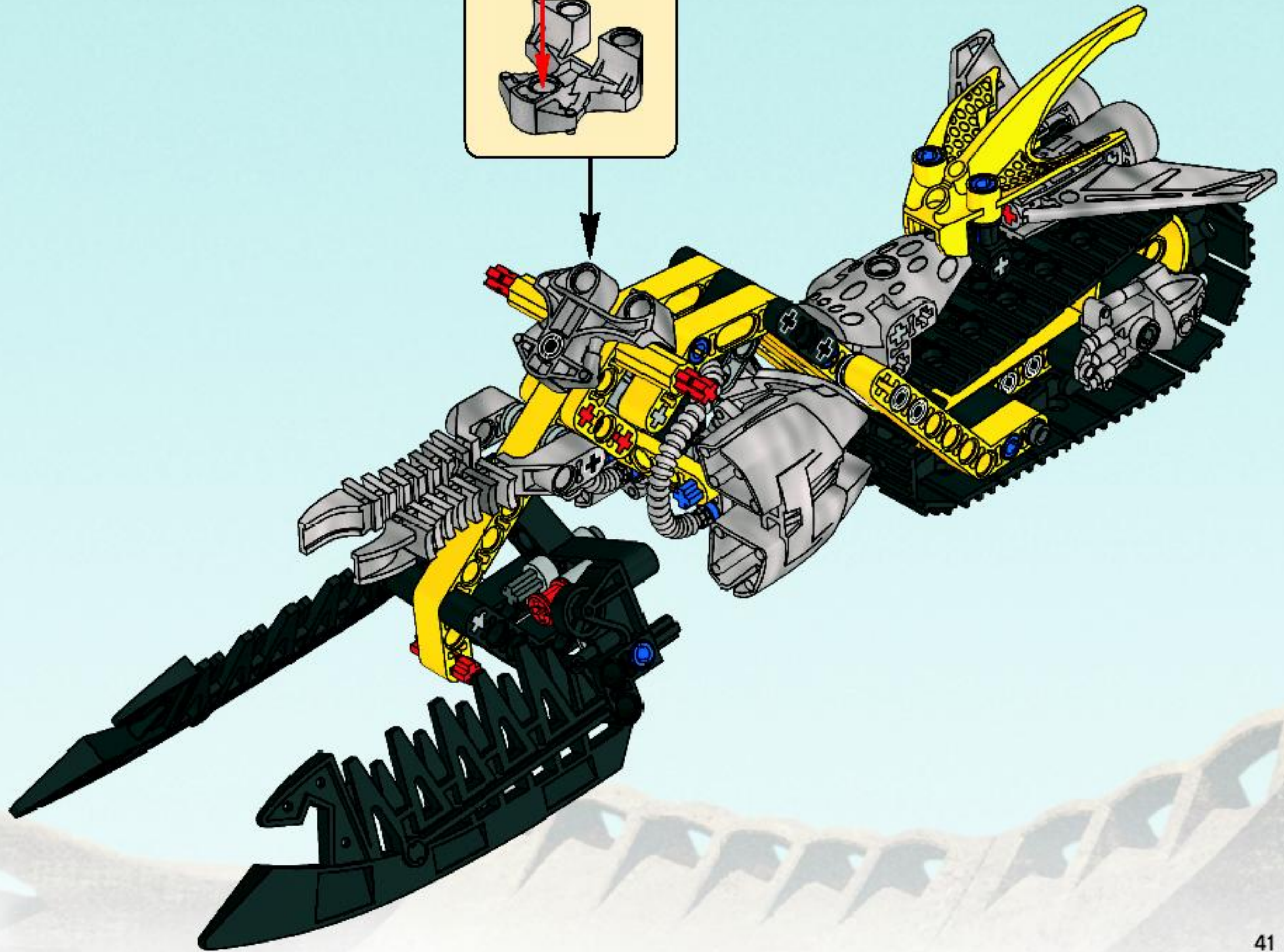
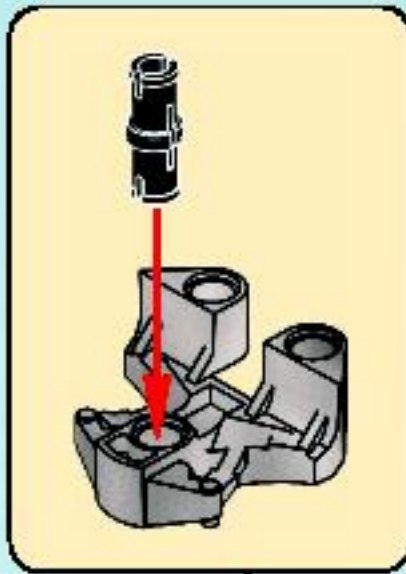





12

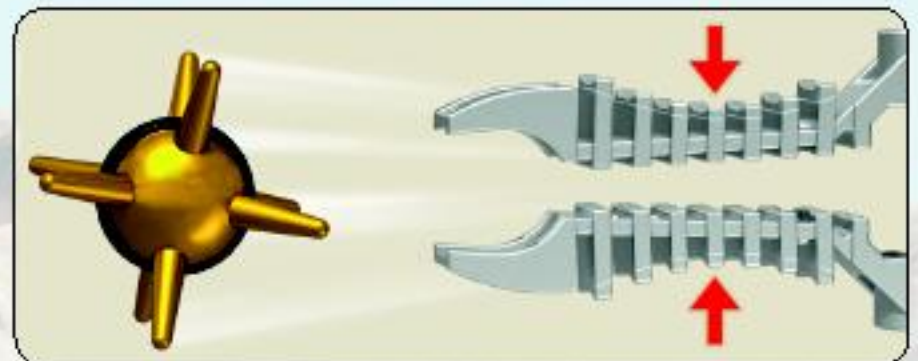
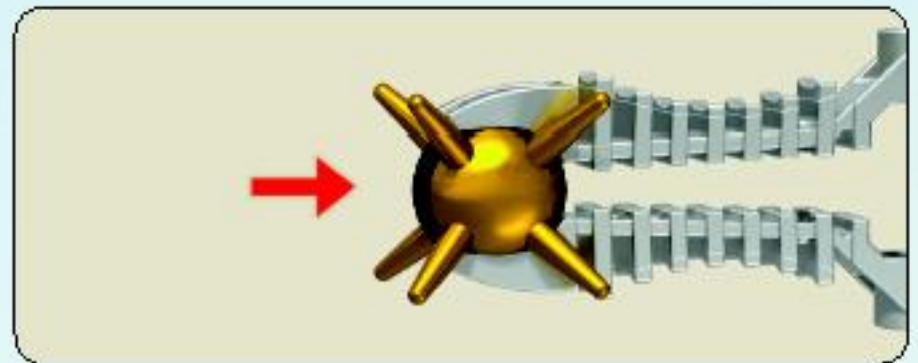



8x  
4142865

4x  
4519010

1x  
4195022



1x  
4546585

2x  
4494481

2x  
4140806

2x  
4112289

4x  
4107081

2x  
4247224

2x  
4546416

4x  
4541500

1x  
4199345

8x  
4121715

2x  
4211573

1x  
4535261

2x  
4526631

2x  
4548195

1x  
4548191

5x  
370526

8x  
4211815

1x  
4544529

2x  
4547364

1x  
4494518

3x  
4119589

1x  
4211639

1x  
4506460

7x  
4206482

1x  
4547513

2x  
4495934

1x  
4544527

3x  
4211775

2x  
4525712

5x  
4514553

1x  
4541509

4x  
4544005

4x  
4177444

3x  
4211779

2x  
4518506

2x  
4143005

2x  
4211050

2x  
4111996

2x  
4142135

1x  
4225033

1x  
4505846

3x  
4211086

4x  
4128593

1x  
4211889

2x  
4107828

2x  
4211741

20x  
4513023

1x  
4537503

Customer Service  
Kundenservice  
Service Consommateurs  
Servicio Al Consumidor

[www.lego.com/service](http://www.lego.com/service) or dial





: 00800 5346 5555

: 1-800-422-5346







 For more rules on advanced multi-figure game play - check out

 Weitere Informationen und Anleitungen für coole Spiele mit mehreren Figuren findest du unter

 Retrouve toutes les règles du jeu multijoueur sur

 Pour plus d'information concernant les règles des jeux de niveau avancé avec plusieurs figurines, visitez

 Para más información sobre instrucciones de juego avanzado con varias figuras, consulta

 Para más información sobre instrucciones de juego avanzado con varias figuras, consulta





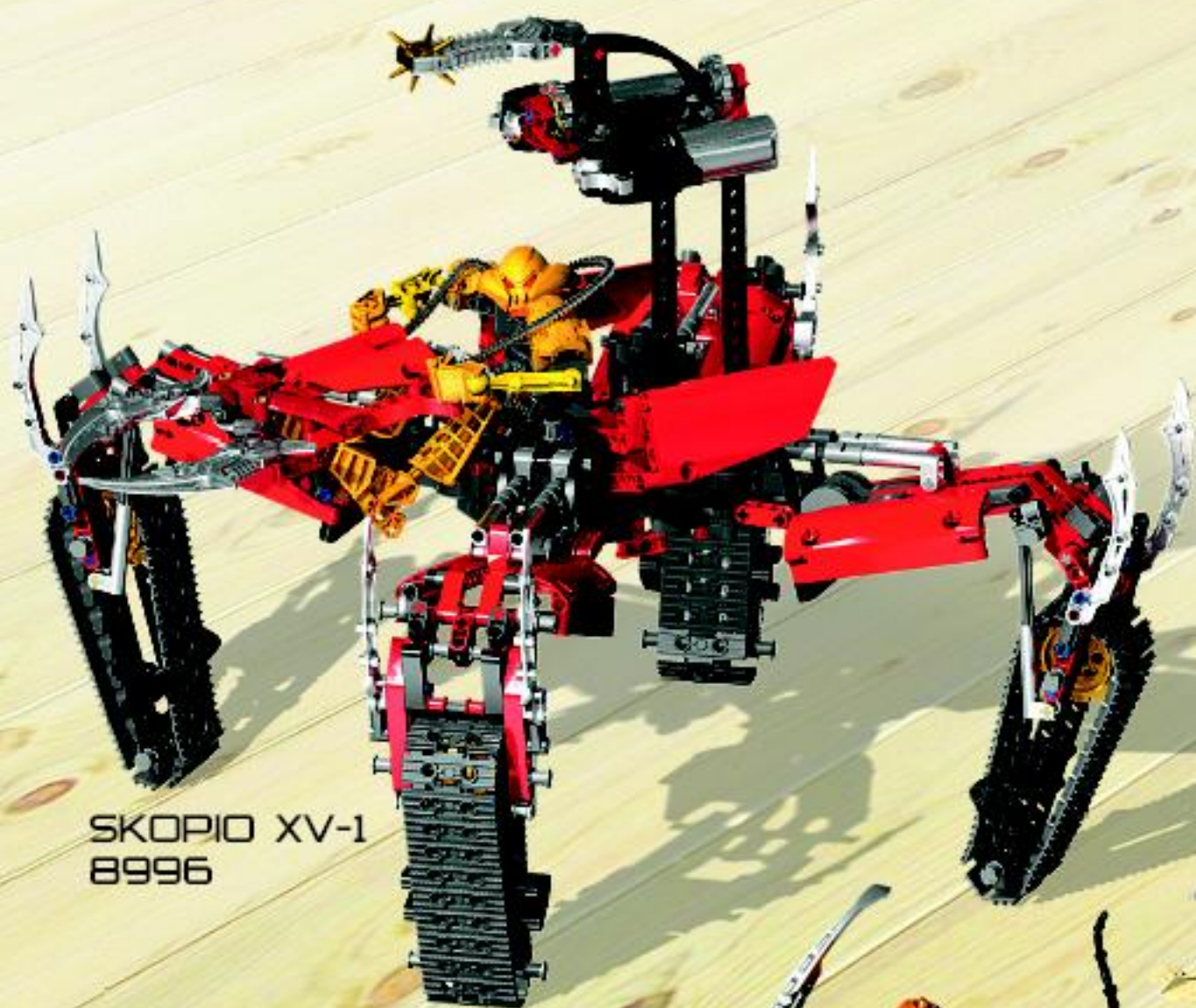

SKOPIO XV-1  
8996



CENDOX V1  
8992

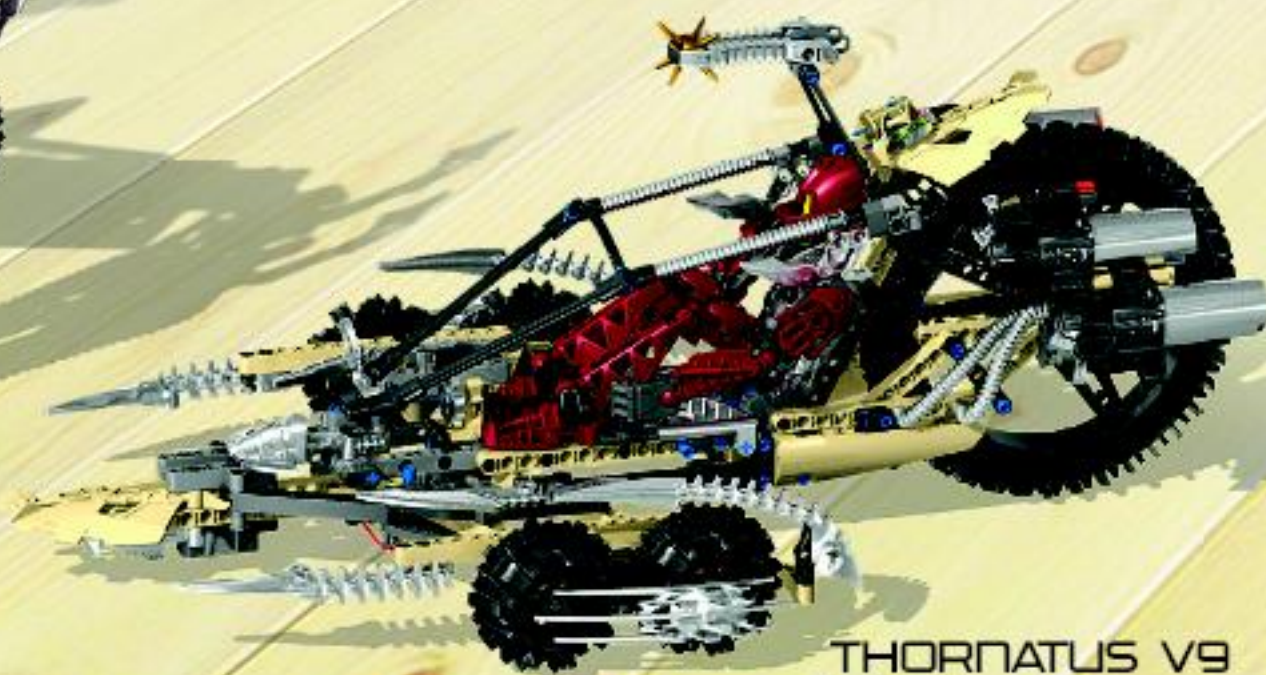

THORNATUS V9  
8995



BARANUS V7  
8994



KAXILUM V3  
8993





ALL-NEW  
MOVIE  
ON DVD

FALL 2009

BRANDNEUER FILM AUF DVD HERBST 2009  
UN TOUT NOUVEAU FILM EN DVD AUTOMNE 2009  
UNA PELÍCULA TOTALMENTE NUEVA EN DVD OTOÑO 2009  
UM FILME COMPLETAMENTE NOVO EM DVD OUTONO 2009  
EGY VADONATÚJ MOZIFILM DVD SZ 2009







[www.nielsen.com/LEGO](http://www.nielsen.com/LEGO)



## WIN LEGO® PRODUCTS

Fill out a survey and you might WIN a cool LEGO product!  
NO PURCHASE NECESSARY

Open to all residents where not prohibited  
Go to [www.nielsen.com/dk/LEGO](http://www.nielsen.com/dk/LEGO) to fill out a survey for a chance to win a LEGO product.

## WIN LEGO® PRODUCTEN

Vul een enquêteformulier in en maak kans op een cool LEGO® product

Kopen niet nodig

Iedereen uit landen waar geen enquêteverbod geldt mag deelnemen.

Ga naar [www.nielsen.nl/dk/LEGO](http://www.nielsen.nl/dk/LEGO), vul een enquêteformulier in en maak kans op een LEGO product.

## GEWINNE LEGO® PRODUKTE

Nimm an der Umfrage teil und GEWINNE ein tolles LEGO® Produkt

Die Teilnahme am Gewinnspiel führt zu keinerlei Kaufverpflichtungen

Teilnahme in allen nicht ausgeschlossenen Ländern möglich

Wir verlosen unter allen Teilnehmern der Umfrage auf [www.nielsen.nl/dk/LEGO](http://www.nielsen.nl/dk/LEGO) LEGO Produkte.

## GAGNE DES PRODUITS LEGO®

Réponds à un questionnaire et tu pourrais GAGNER un produit LEGO® très cool !

Aucune obligation d'achat.

Ouvert à tous les résidents des pays autorisés.

Visite [www.nielsen.nl/dk/LEGO](http://www.nielsen.nl/dk/LEGO) pour répondre à un questionnaire et avoir une chance de gagner un produit LEGO.

## レゴ®製品を「当てよう」

アンケートに記入して、かっこいいレゴ®製品を当てよう！

お買い上げの必要はありません。

禁止されていない限り、すべての管轄にご利用いただけます。

[www.nielsen.nl/dk/LEGO](http://www.nielsen.nl/dk/LEGO)にアクセスして、アンケートにご記入ください。当選者にはレゴ®製品を差し上げます。



 [www.LEGO.com](http://www.LEGO.com)

©2009 The LEGO Group. 4558971