

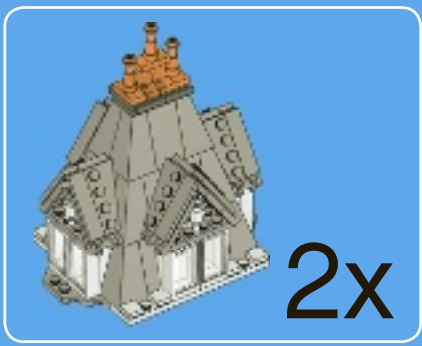

10214





1

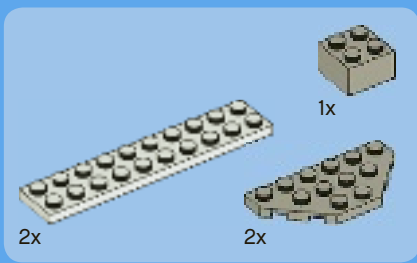
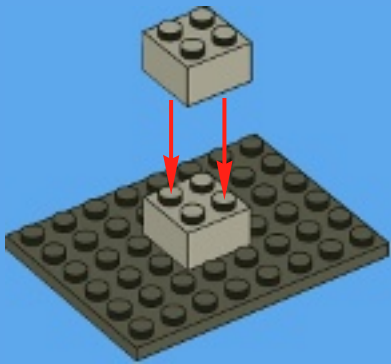

2

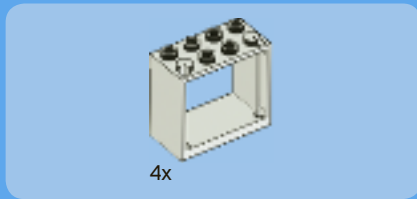
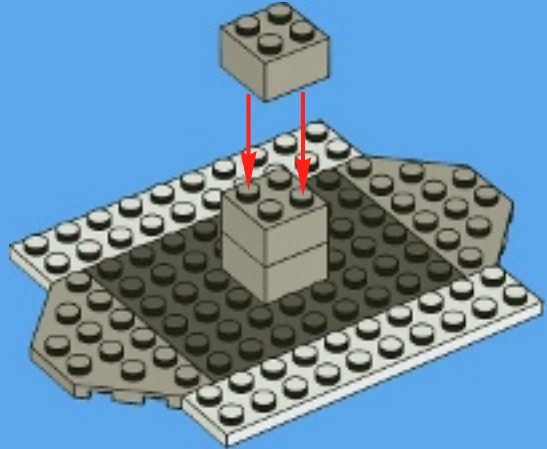

3

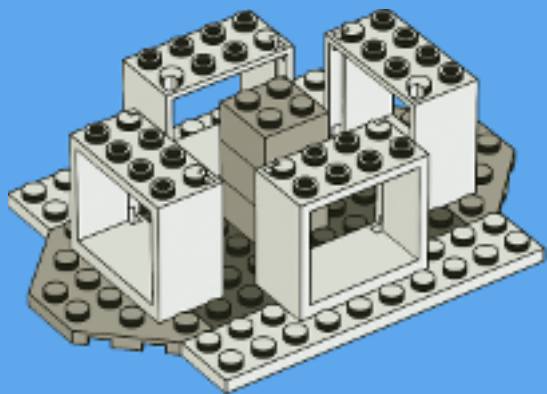



4x



4x

4

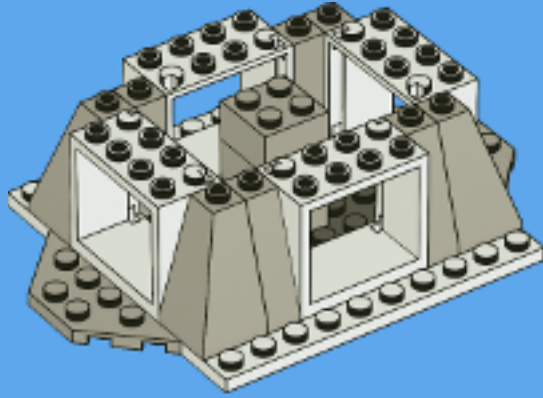

4x



1x

5

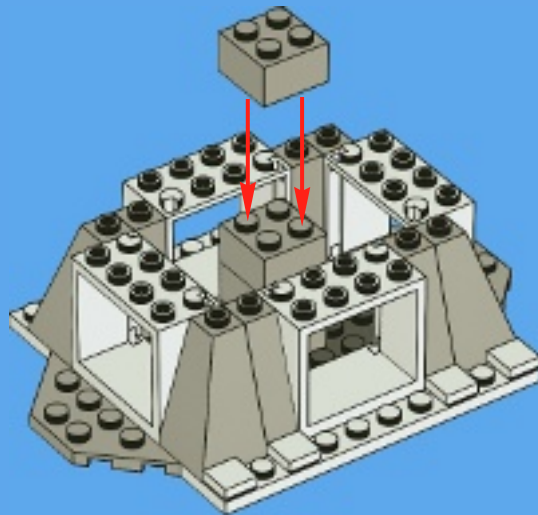



4x



1x

6

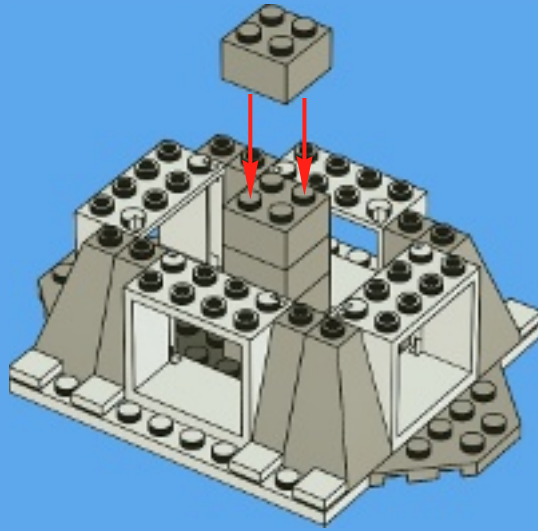

1x

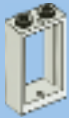

8x



8x

7

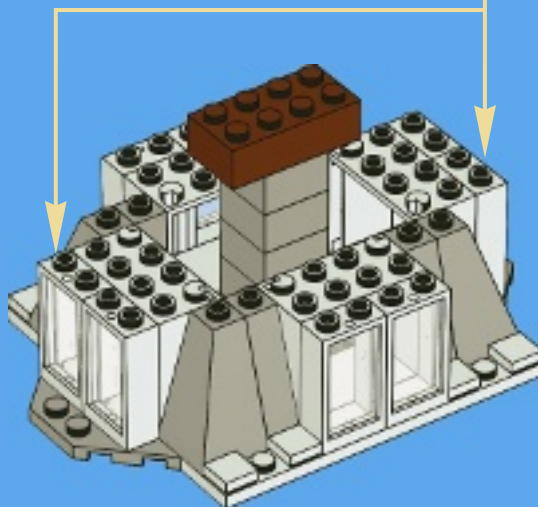
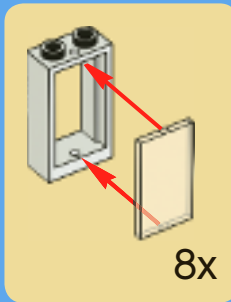



4x



6x

8

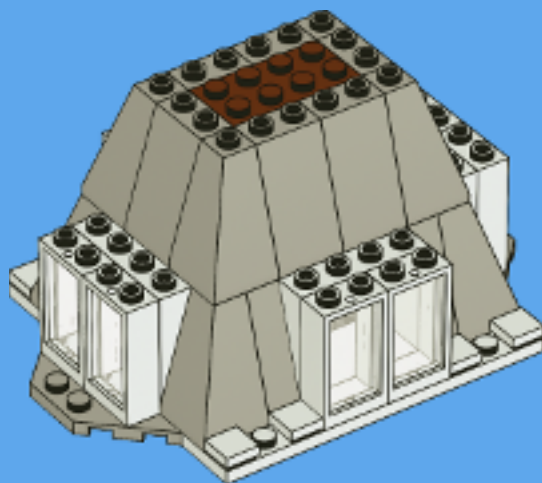

4x



4x



4x



4x

9

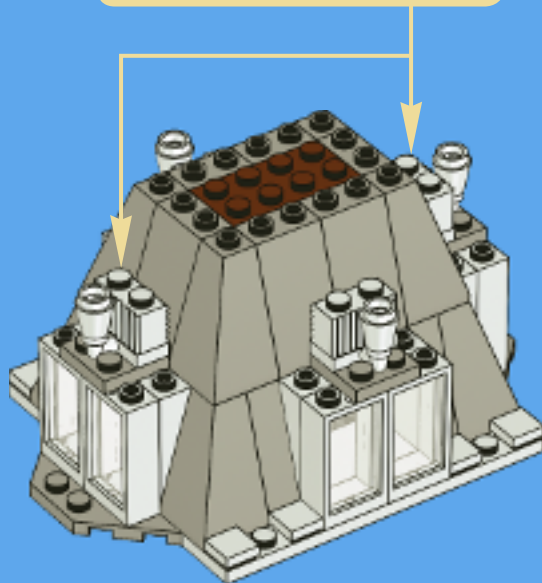
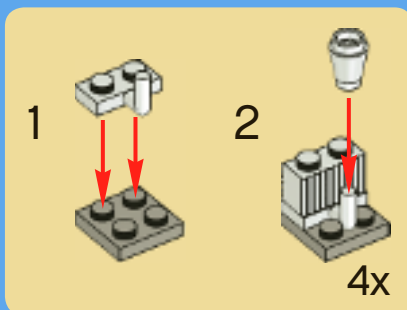

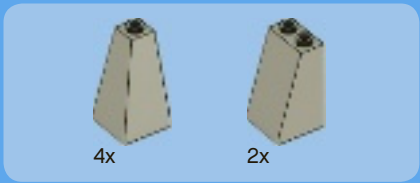

10

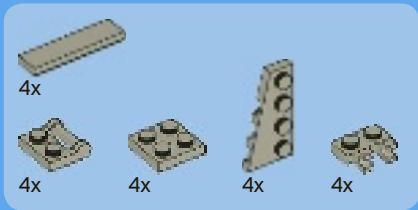
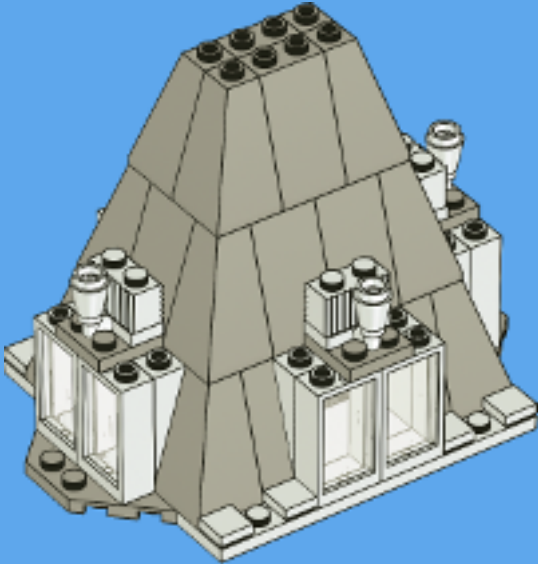

11

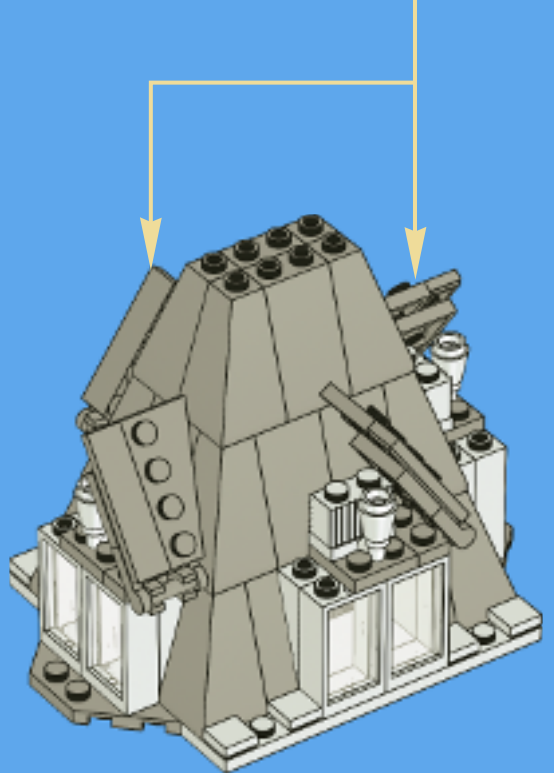
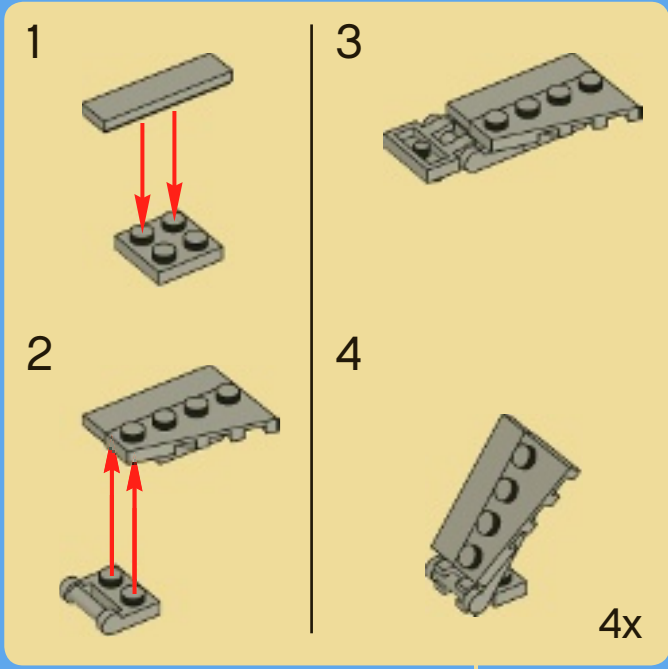

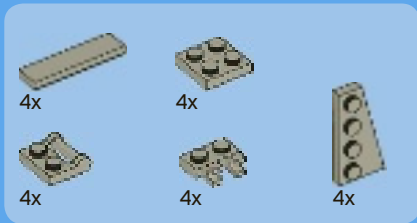

12

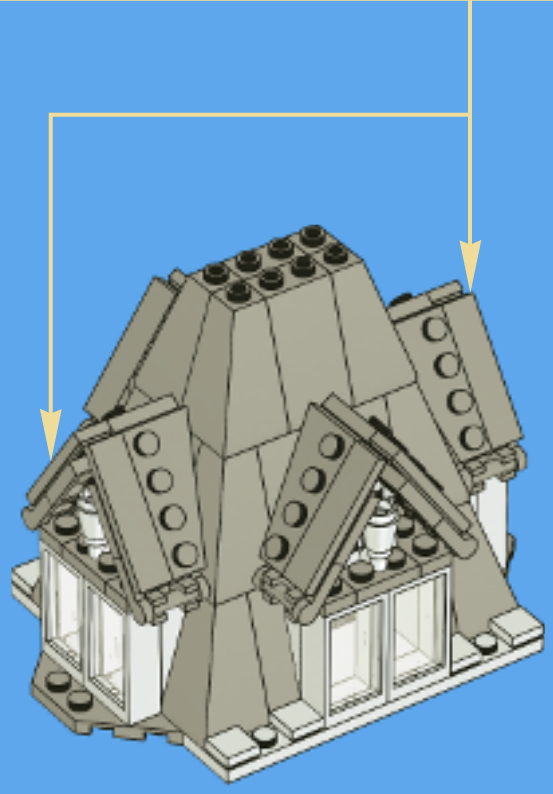
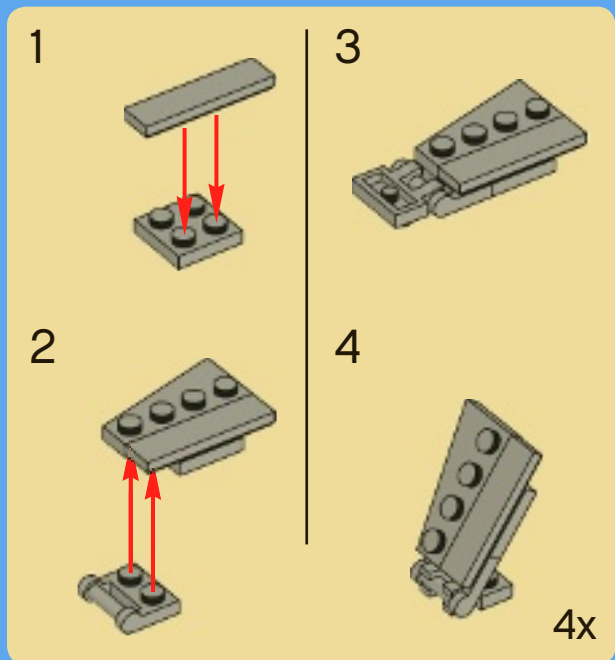

13

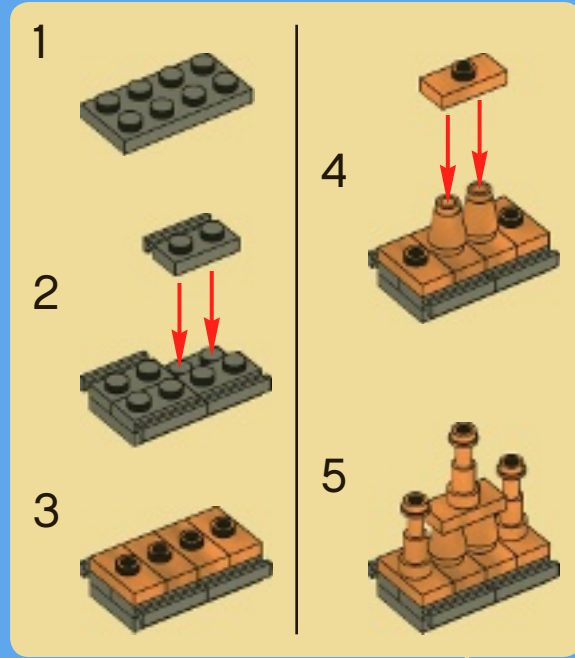

2x
7

14

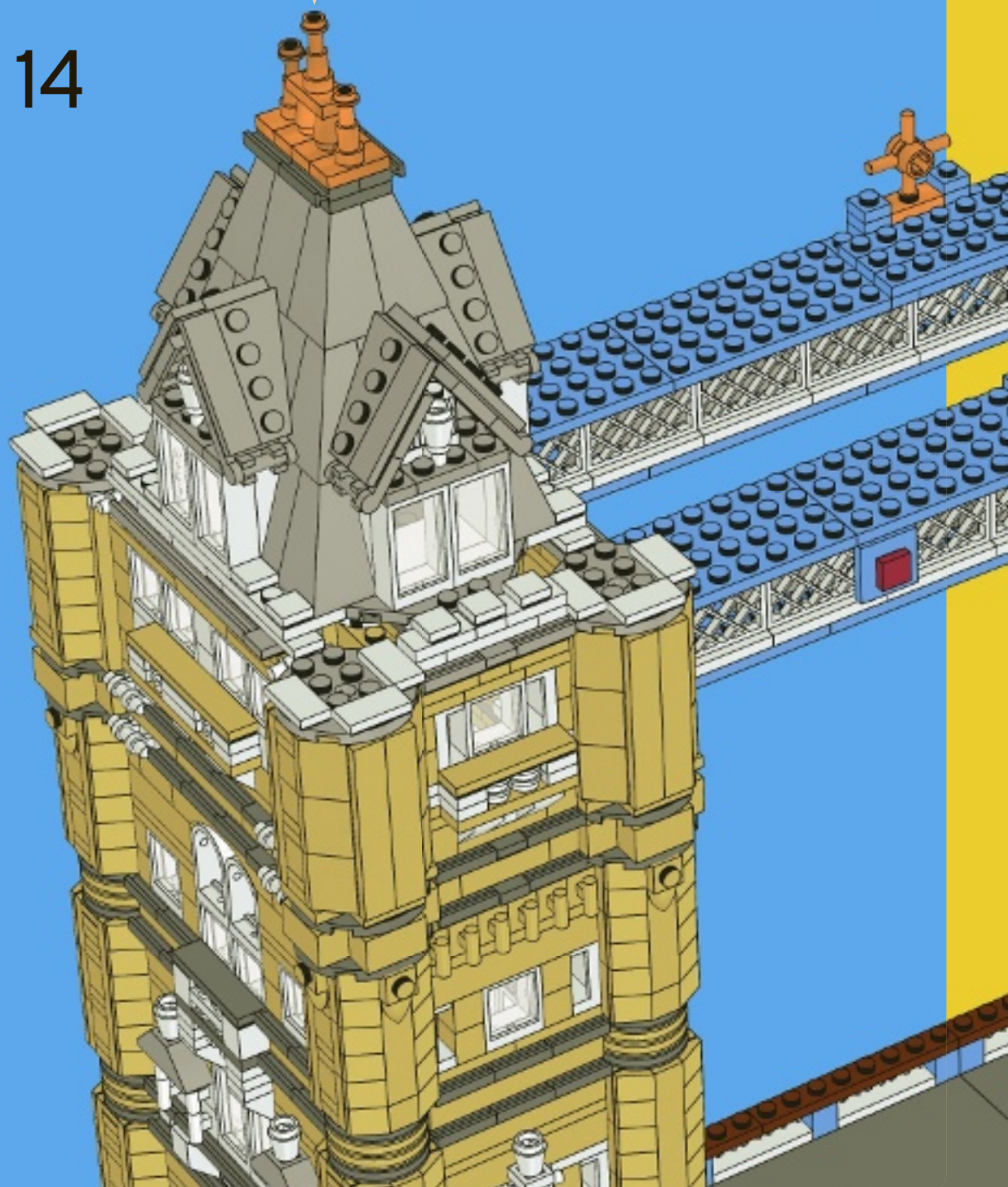

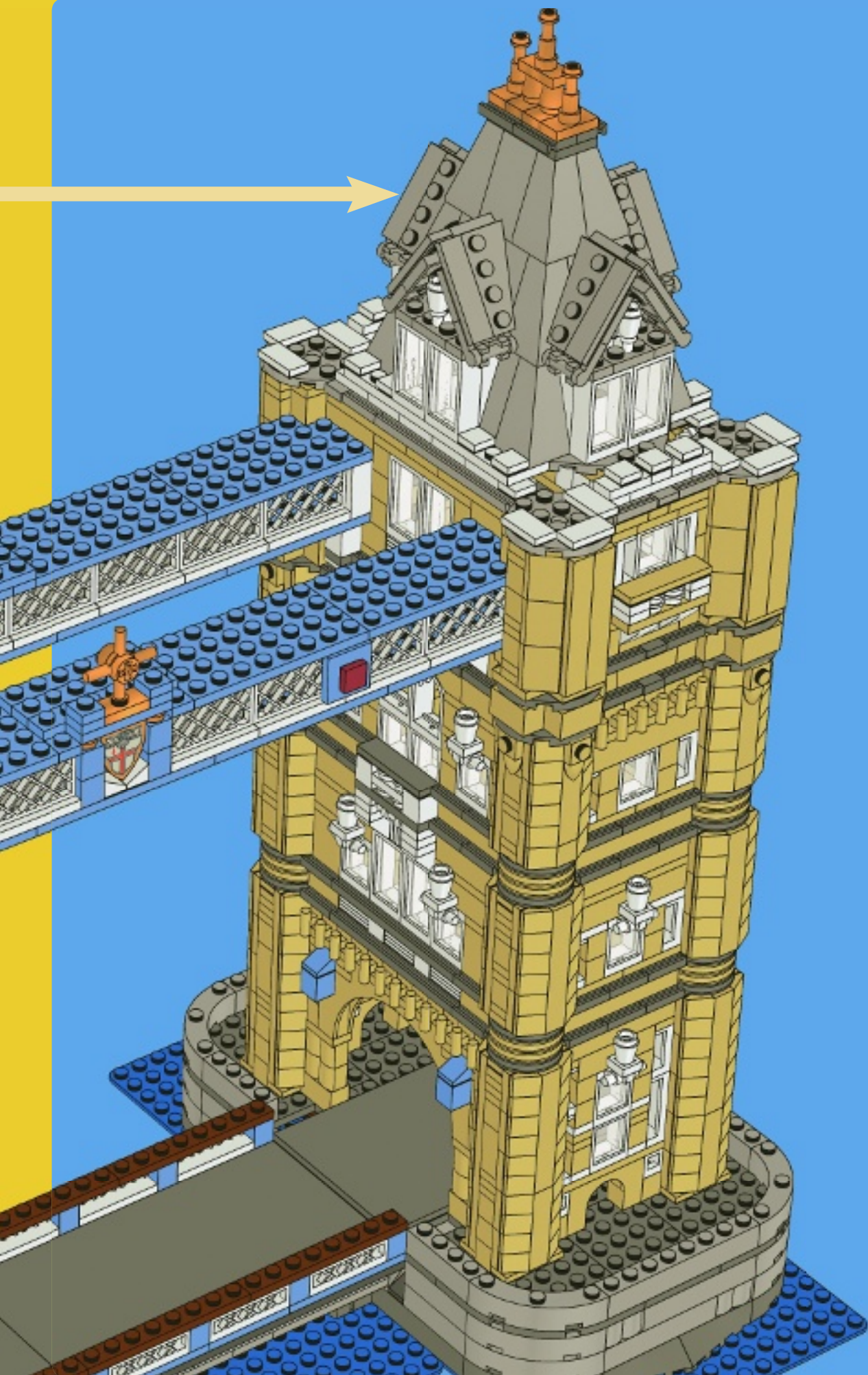

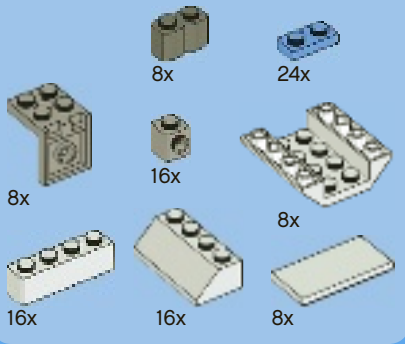

15

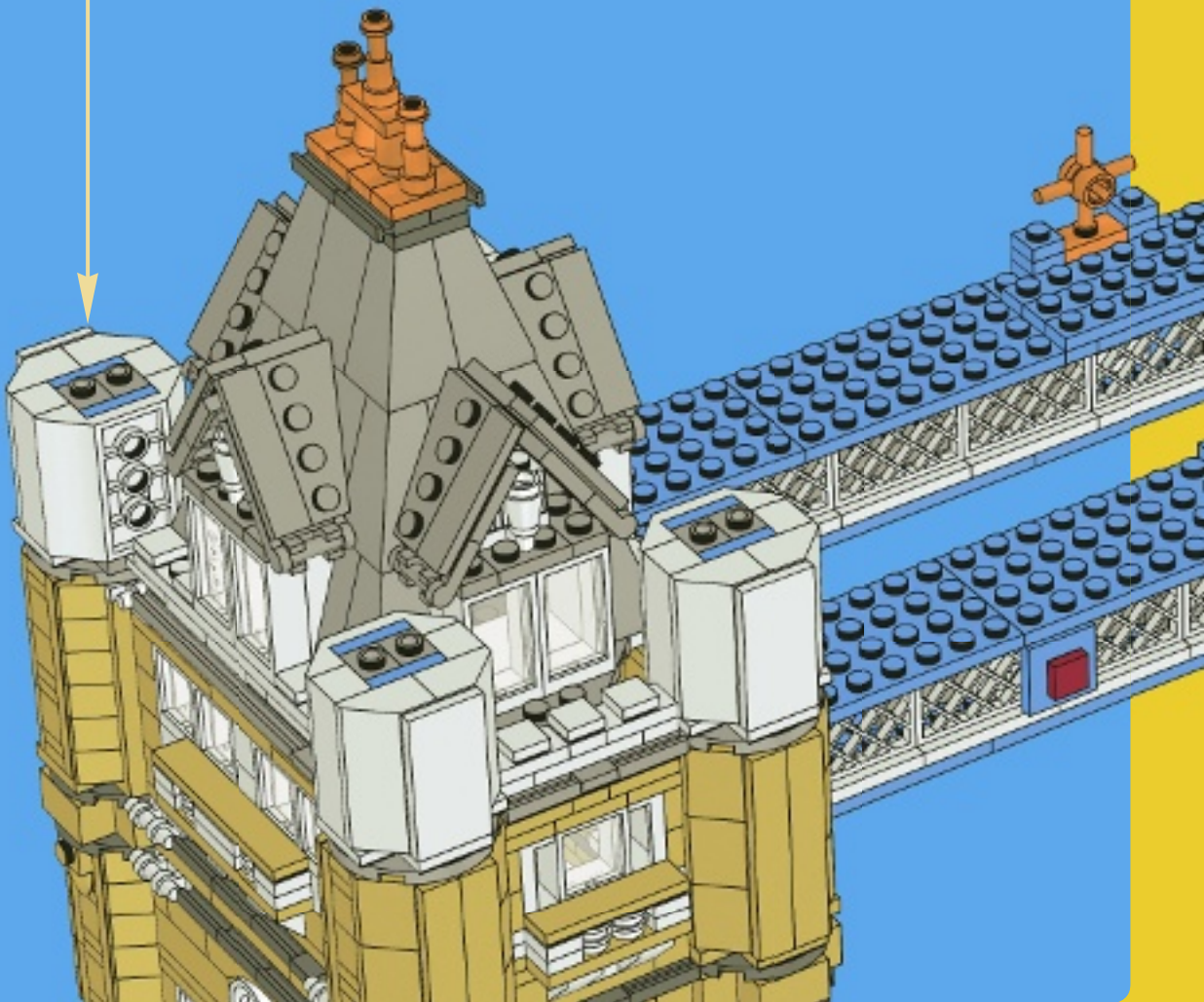
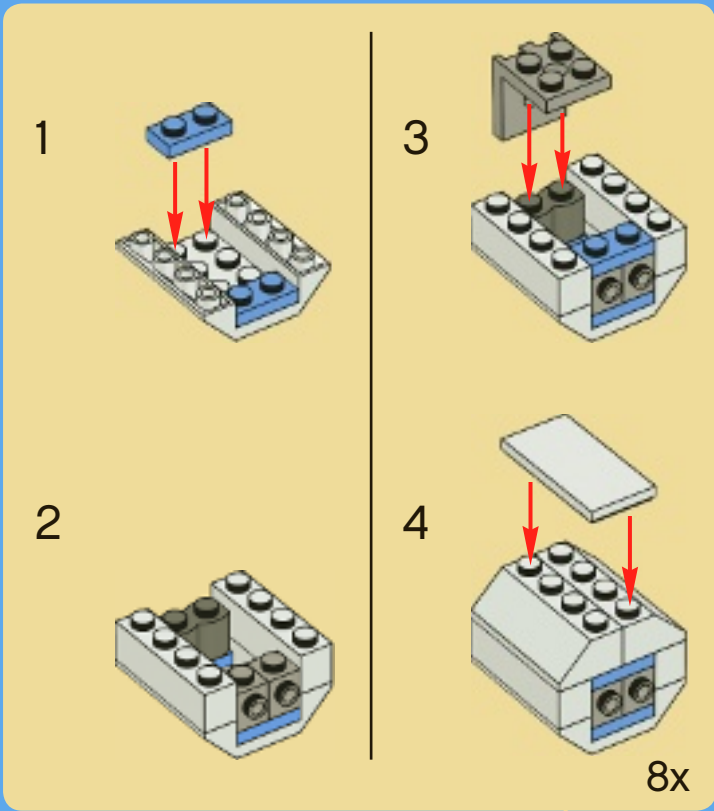

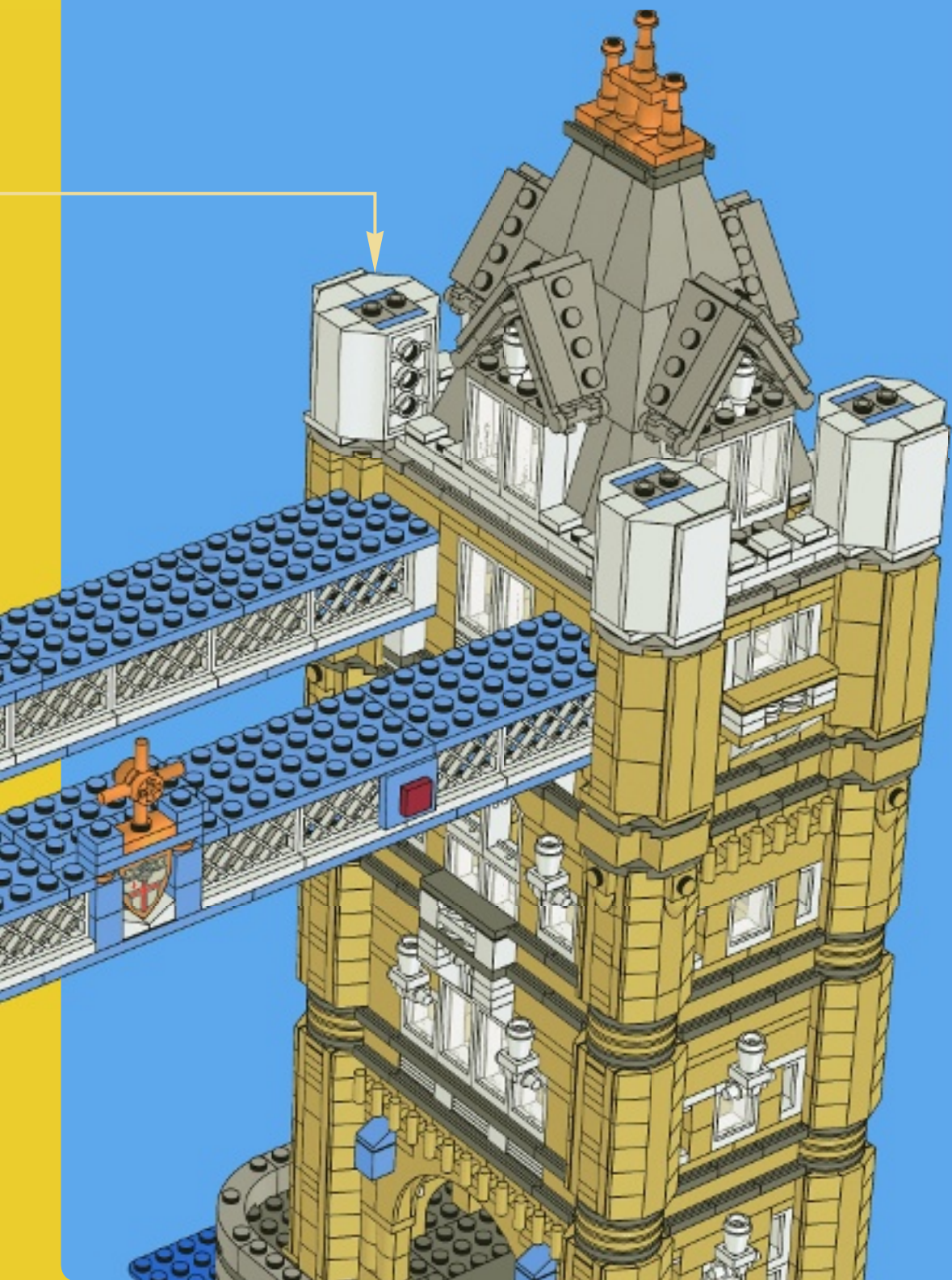

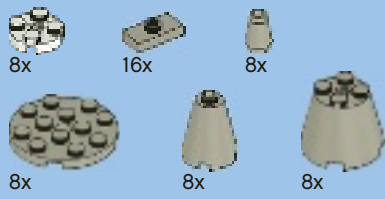

16

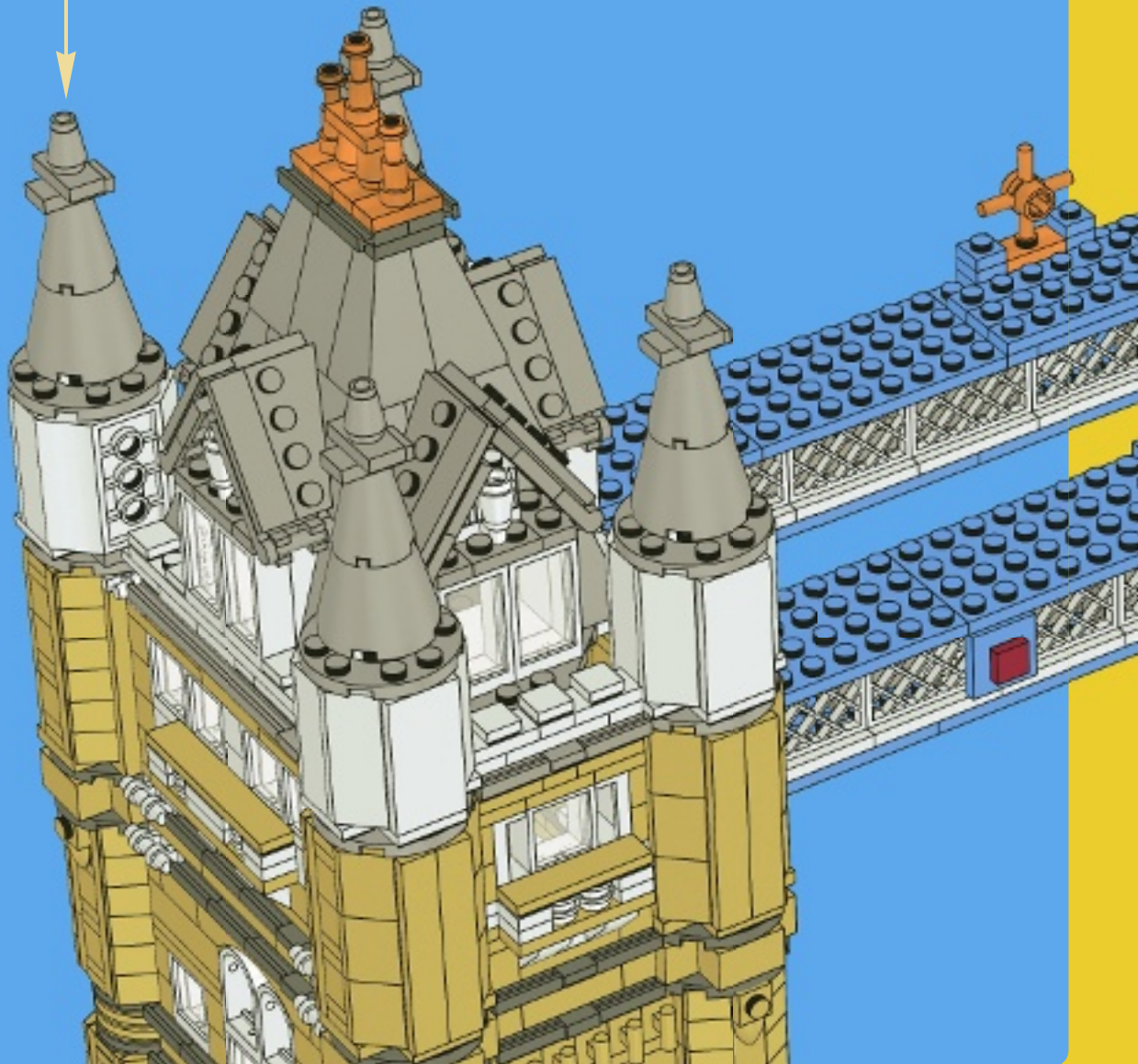
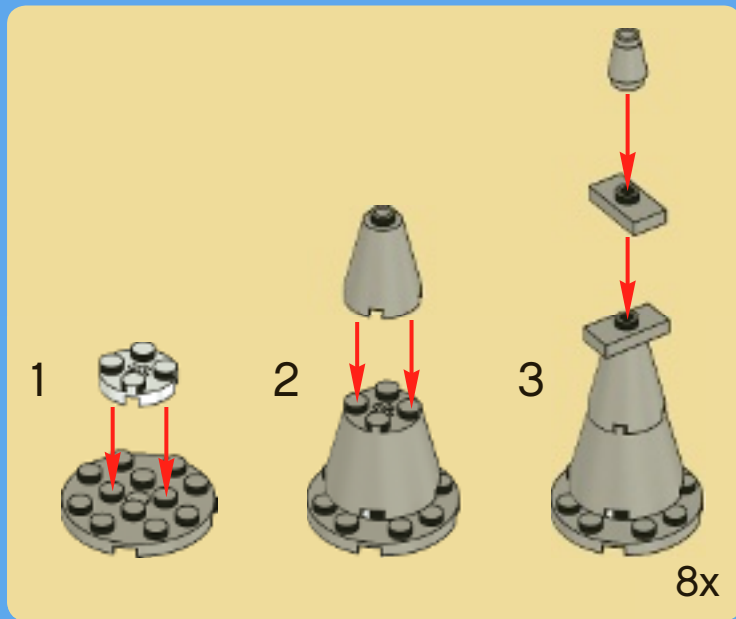

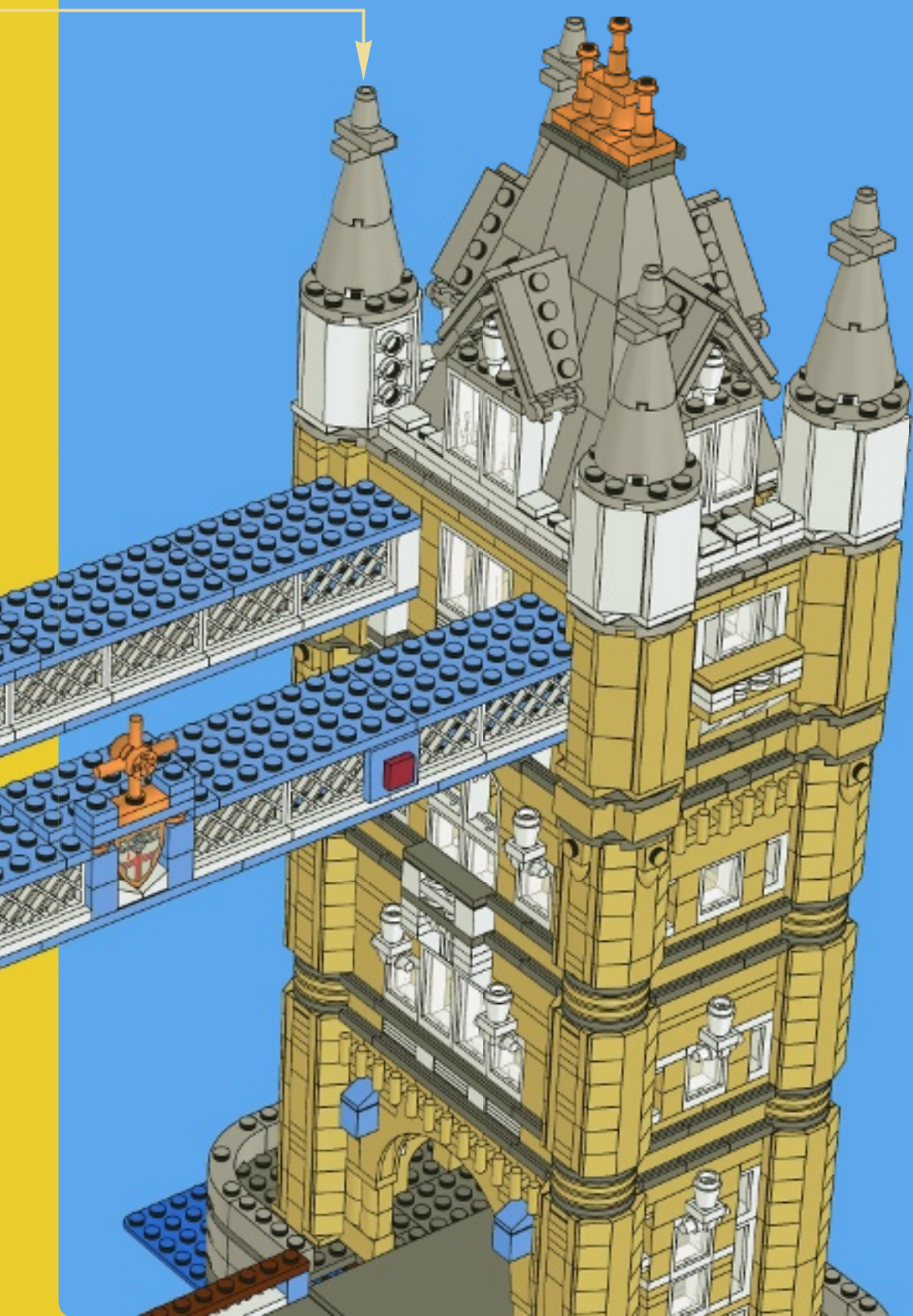

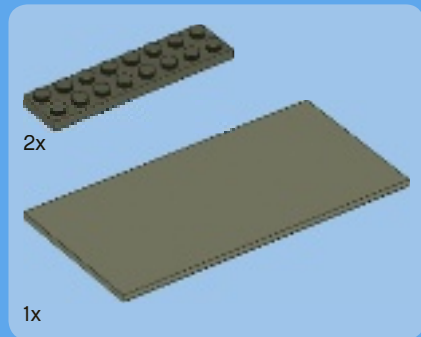
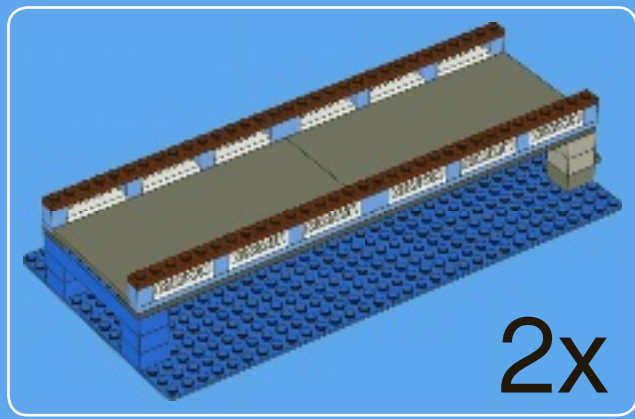

1

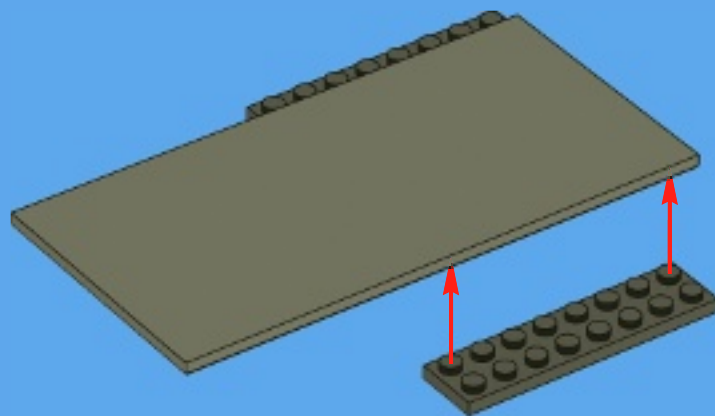

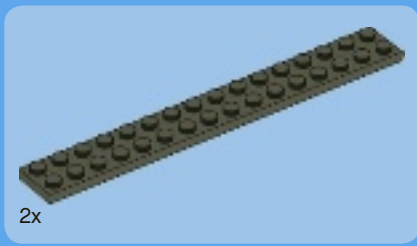

2x

2

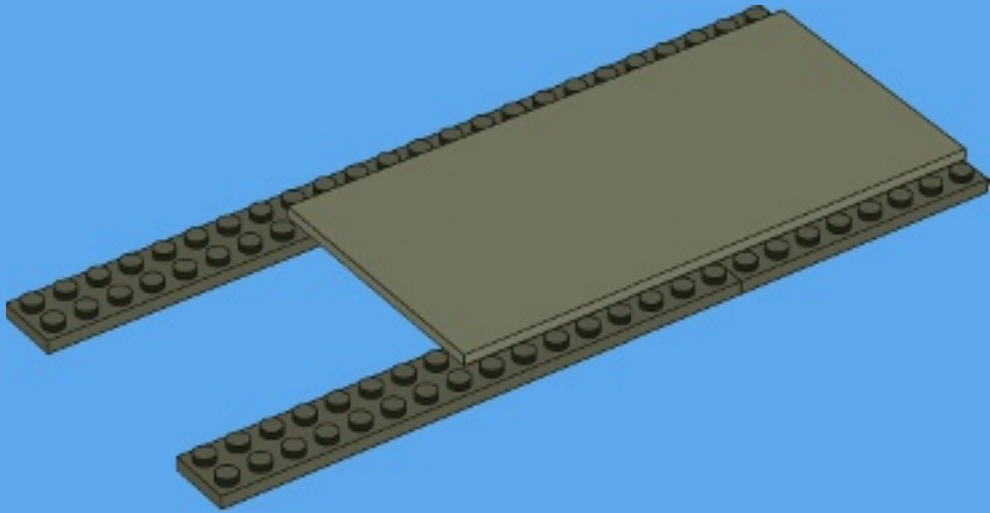



2x

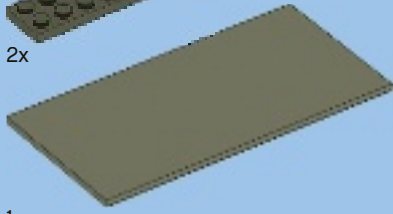

1x

3

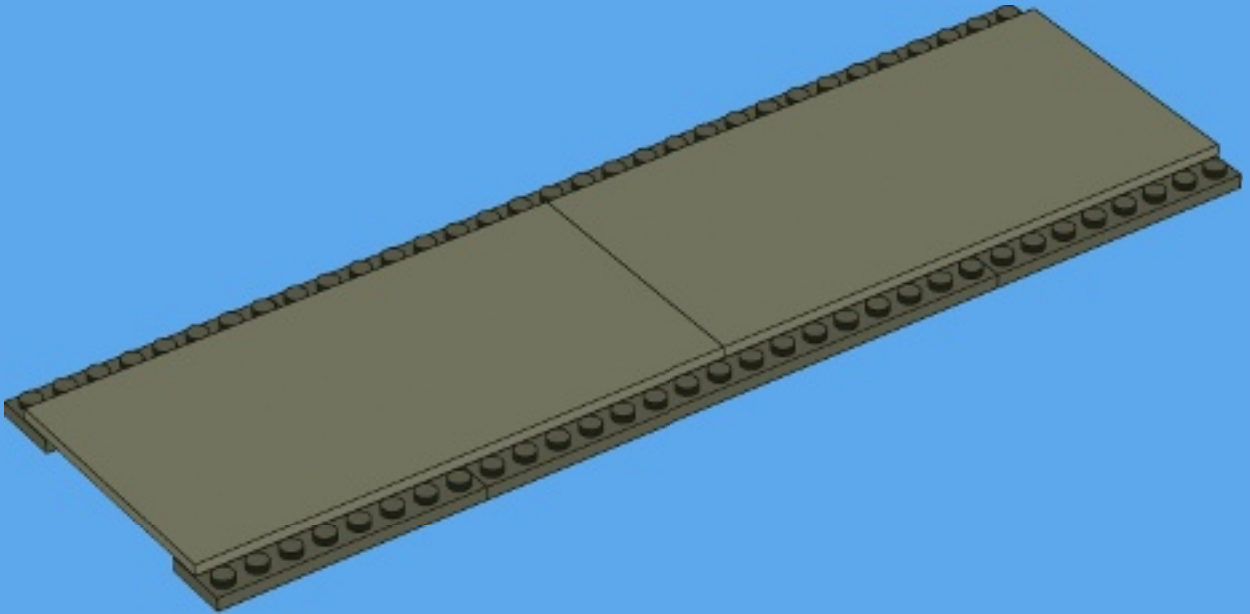



4x



8x

4

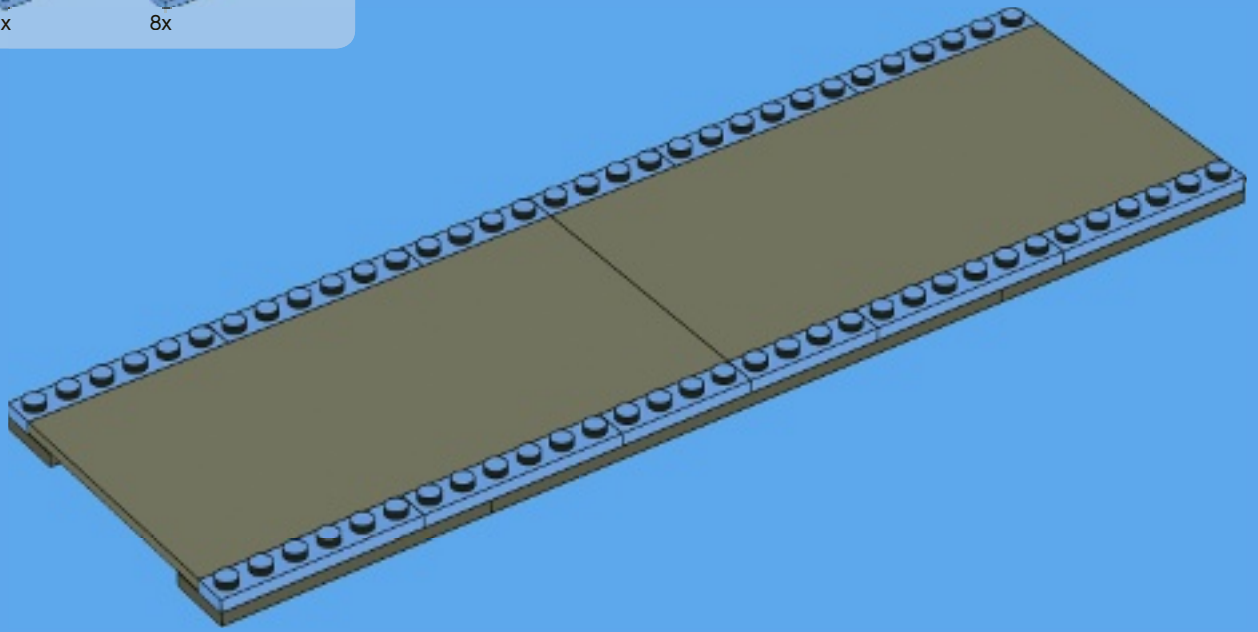

12x



2x



12x

5

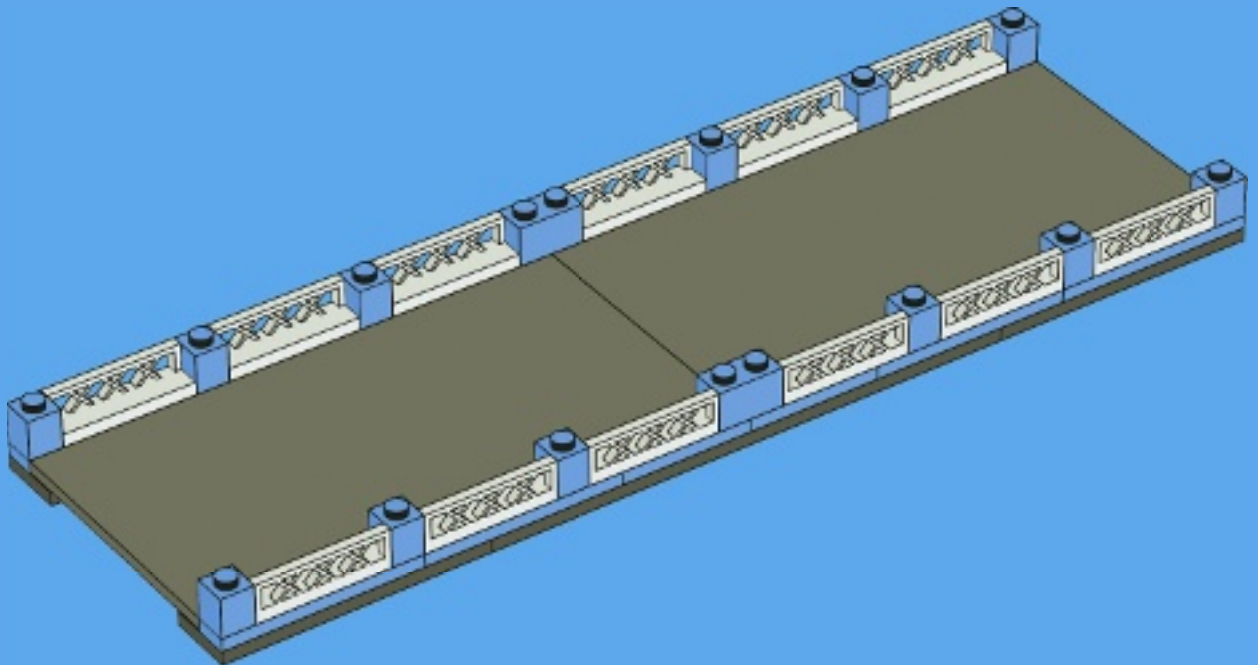



8x

6

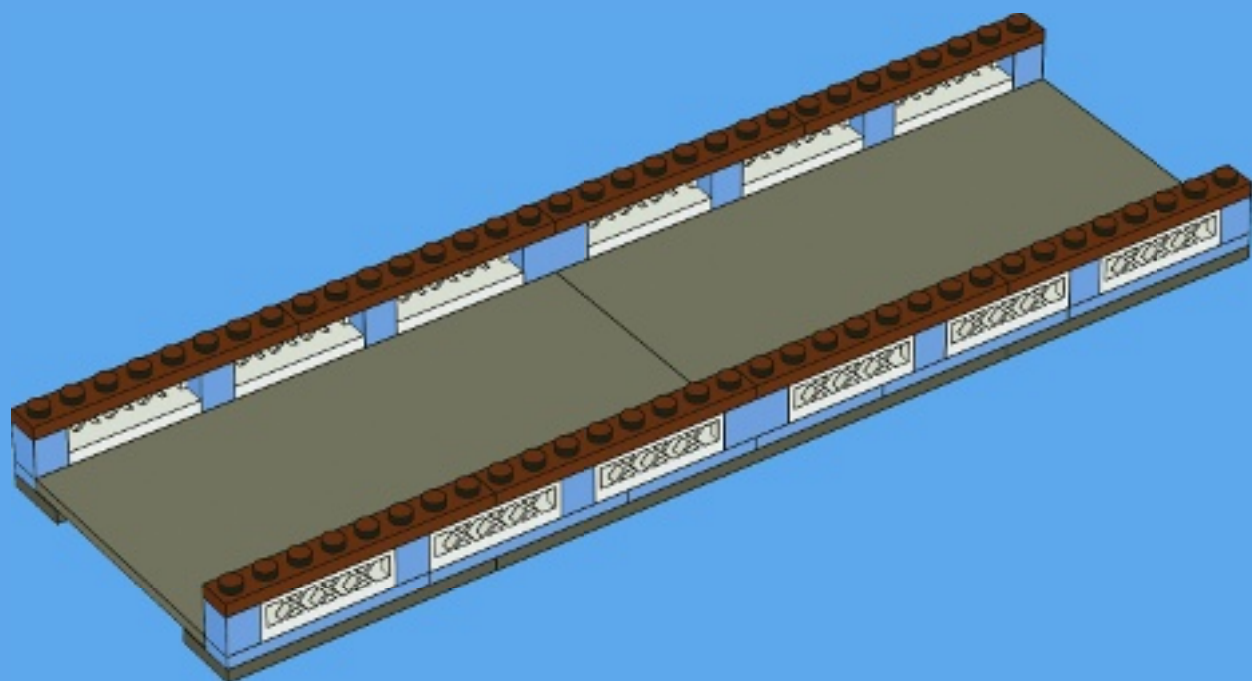

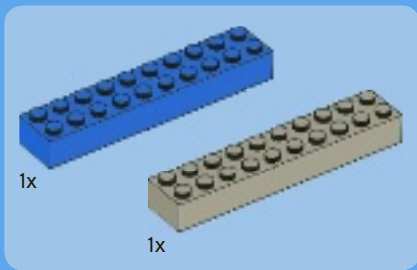

7

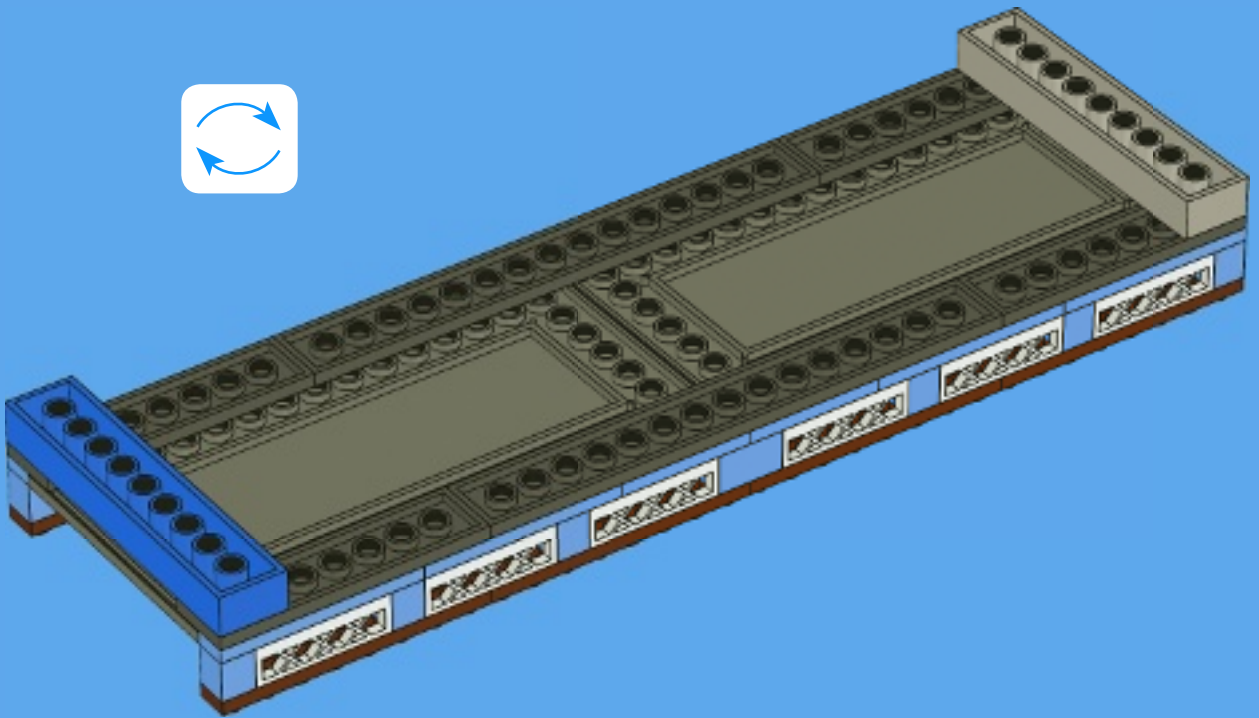



4x



2x



2x

8

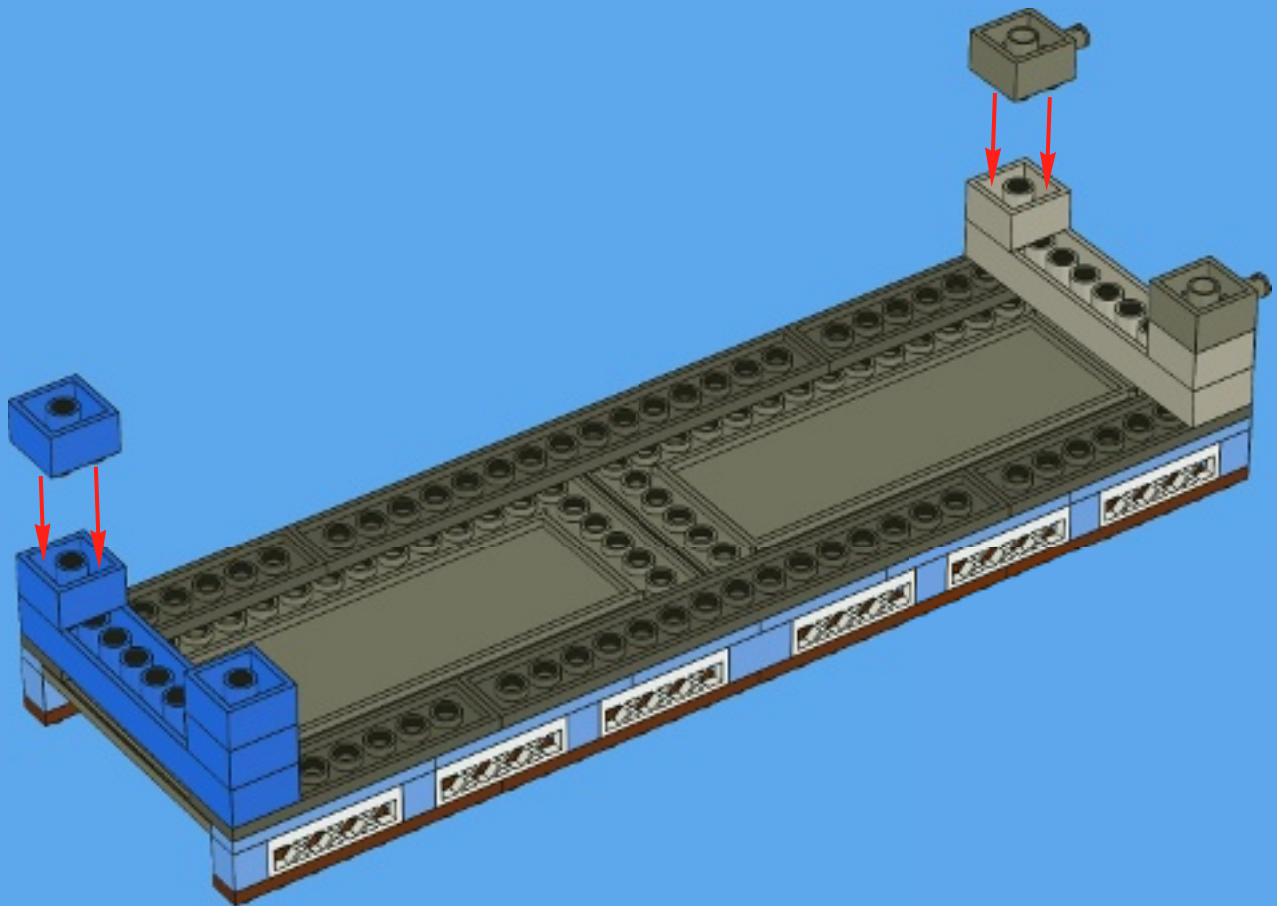

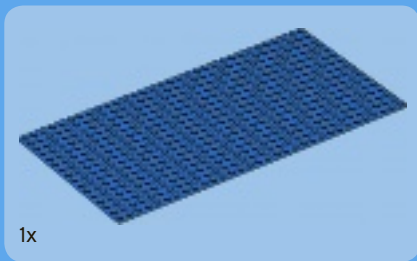

1x

9

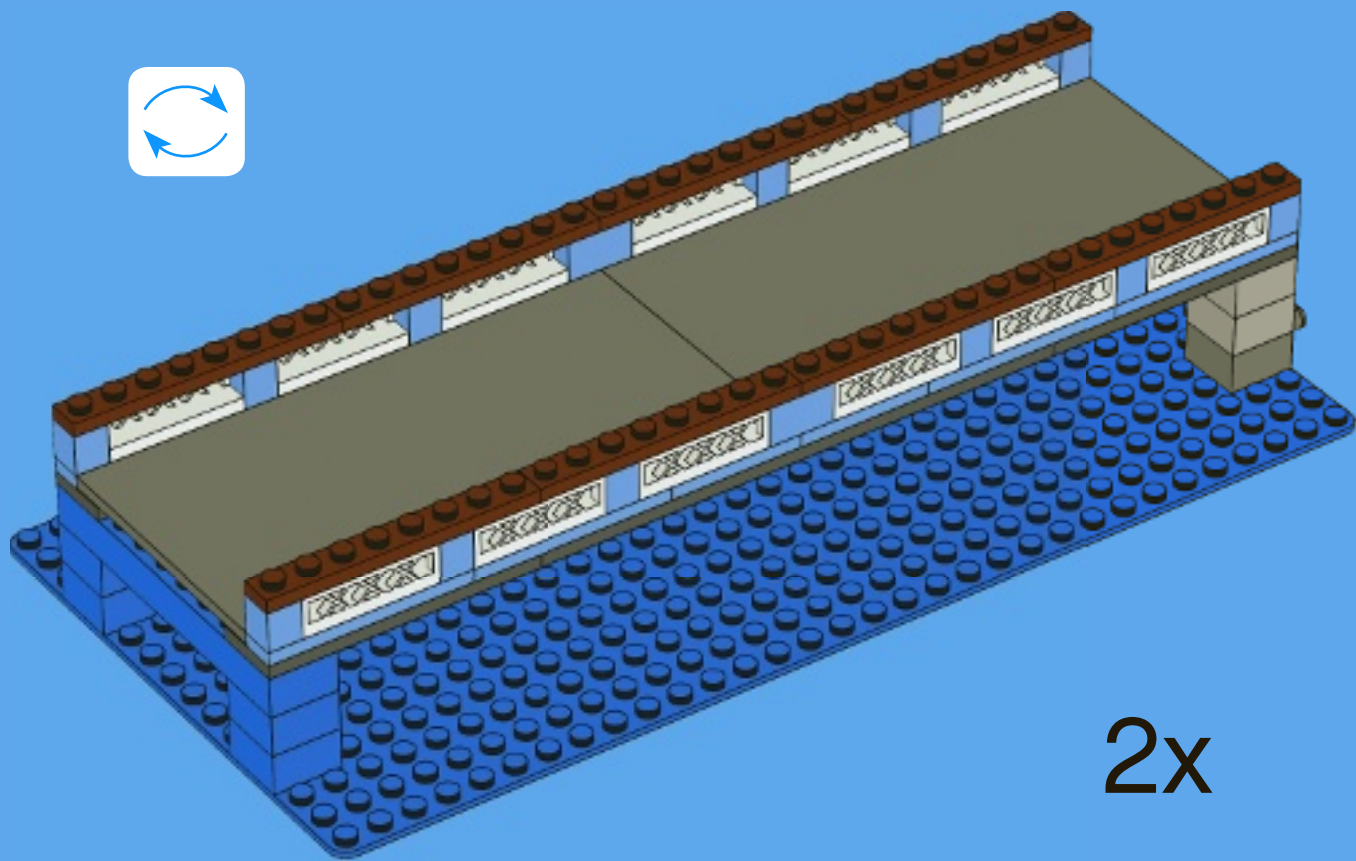

2x

10

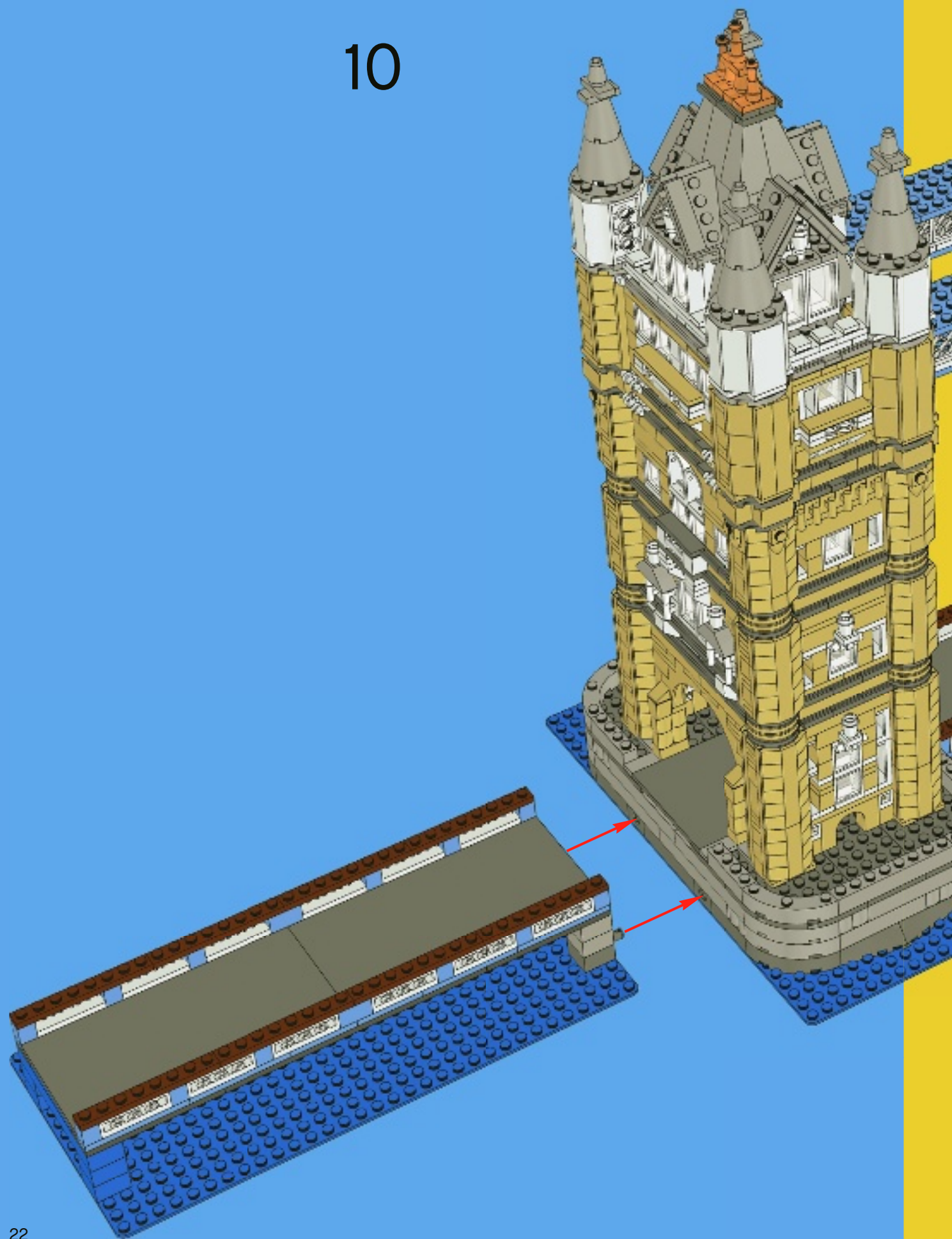

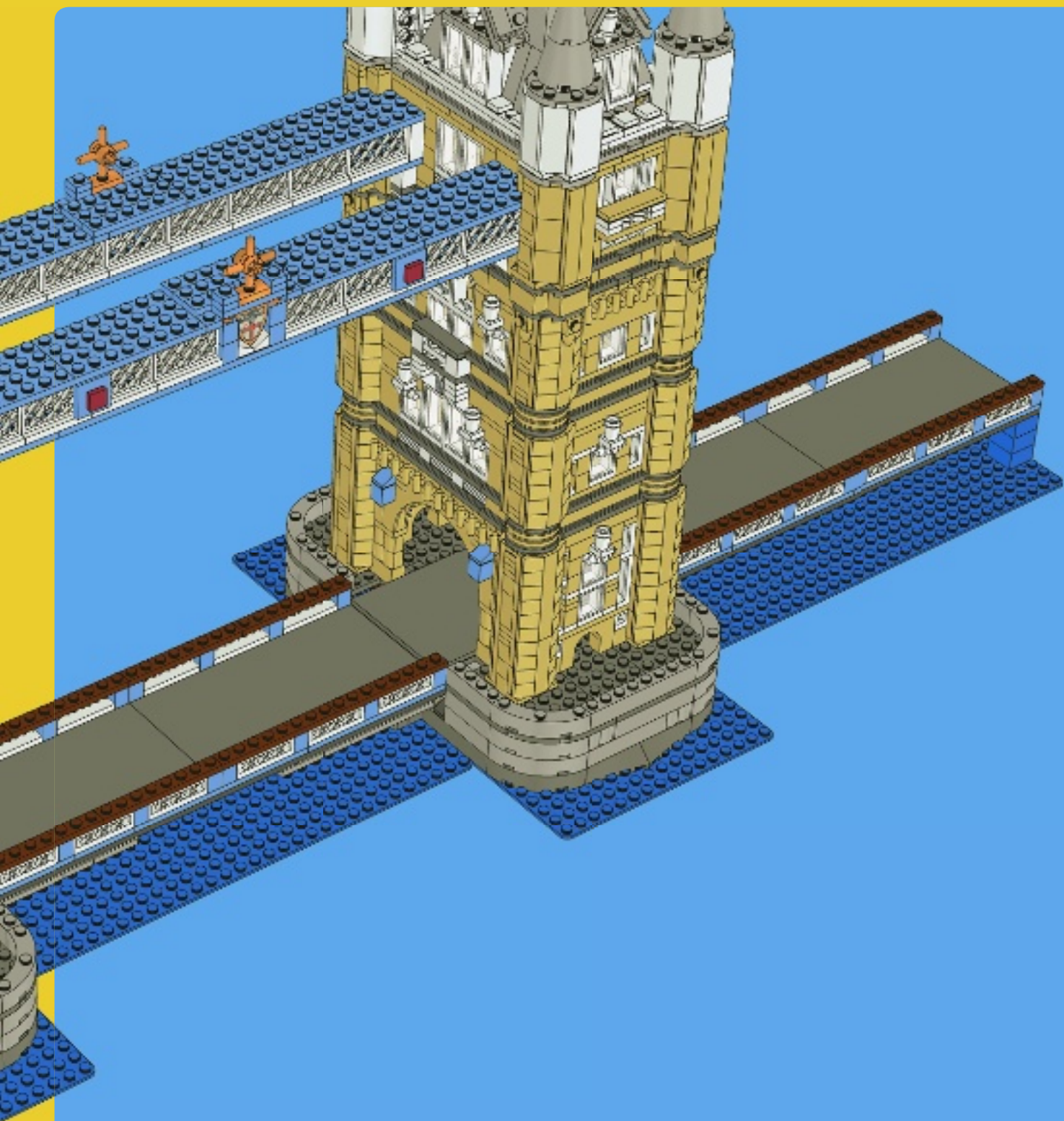

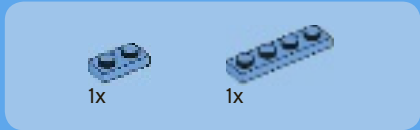

1

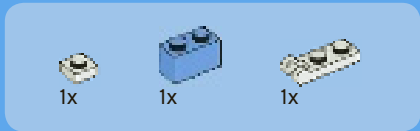
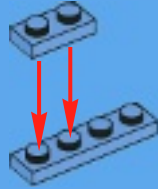

2

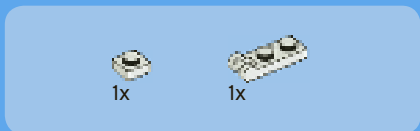
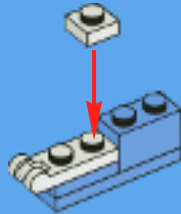

3

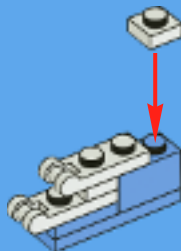



4

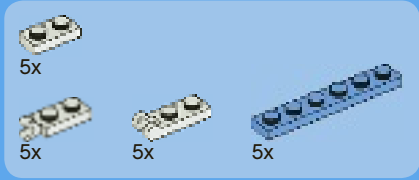
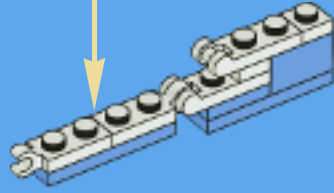
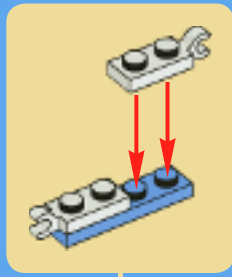

5

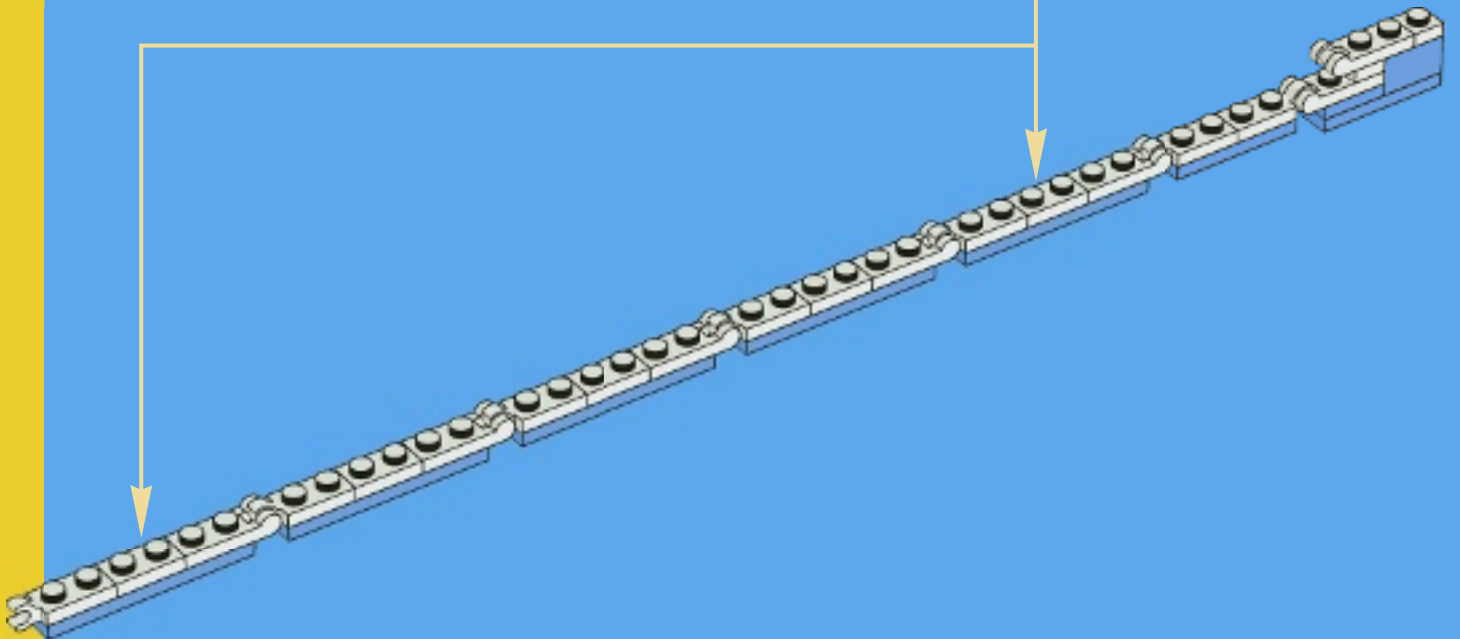
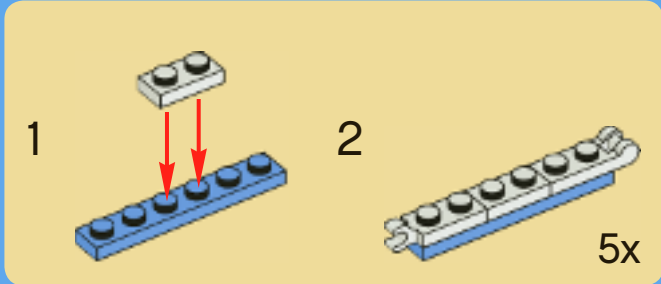



1x



2x

6

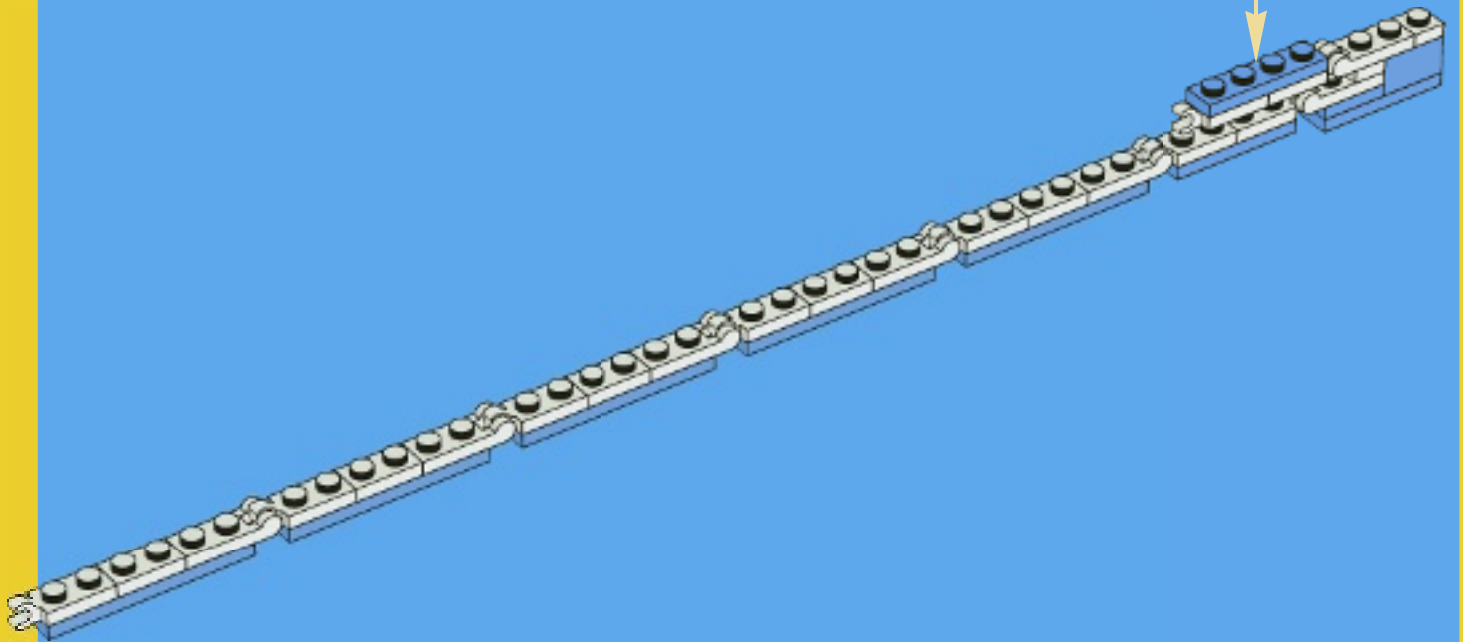
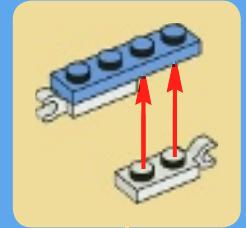

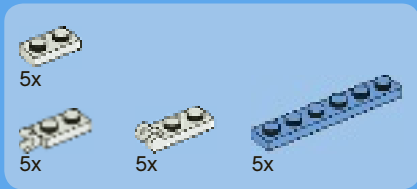

7

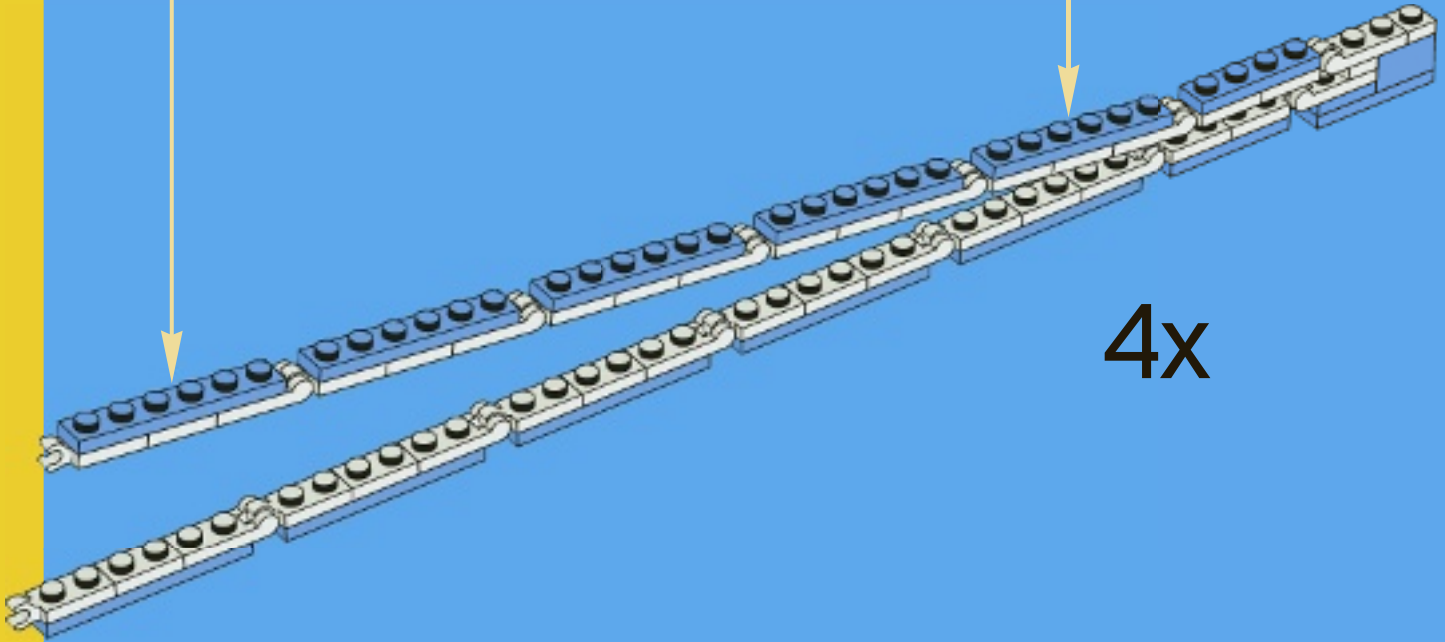
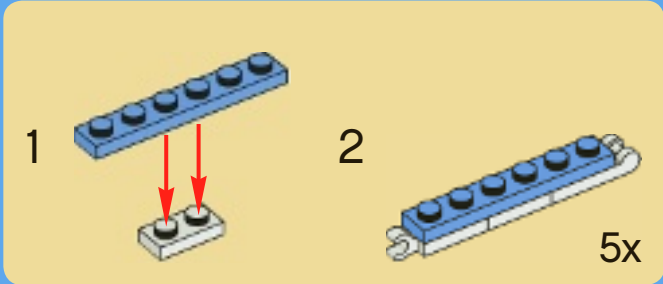

8

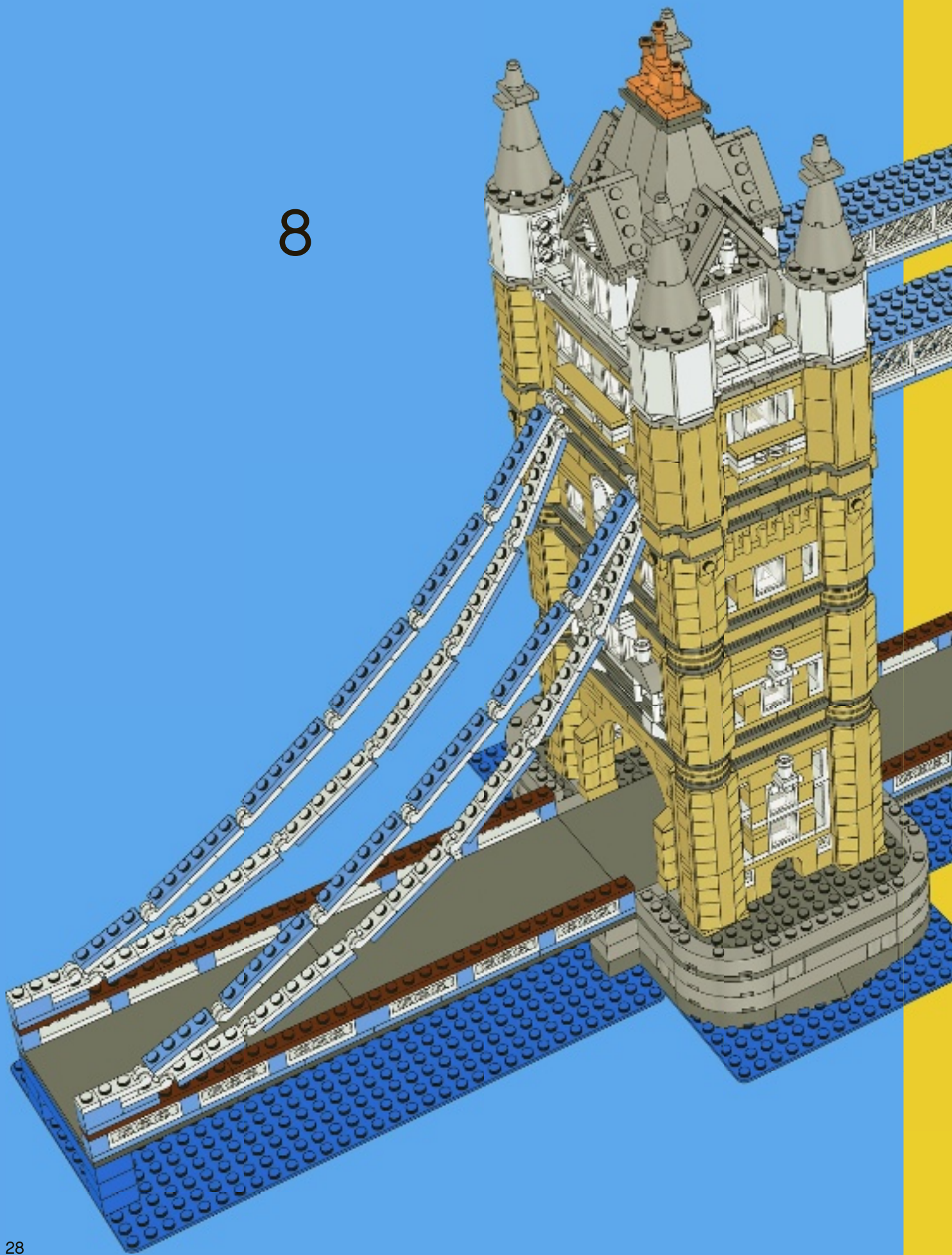

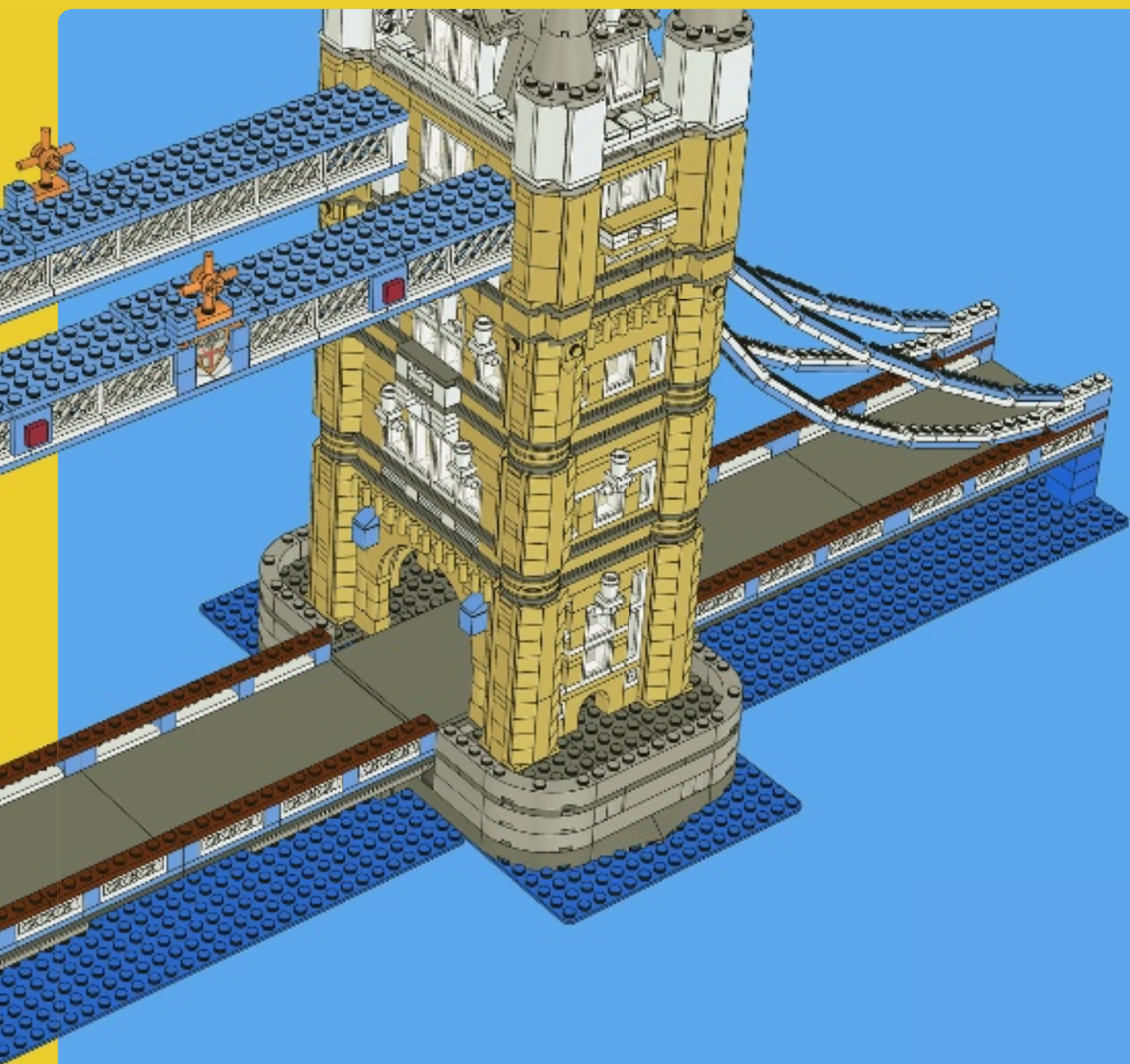



4x



4x



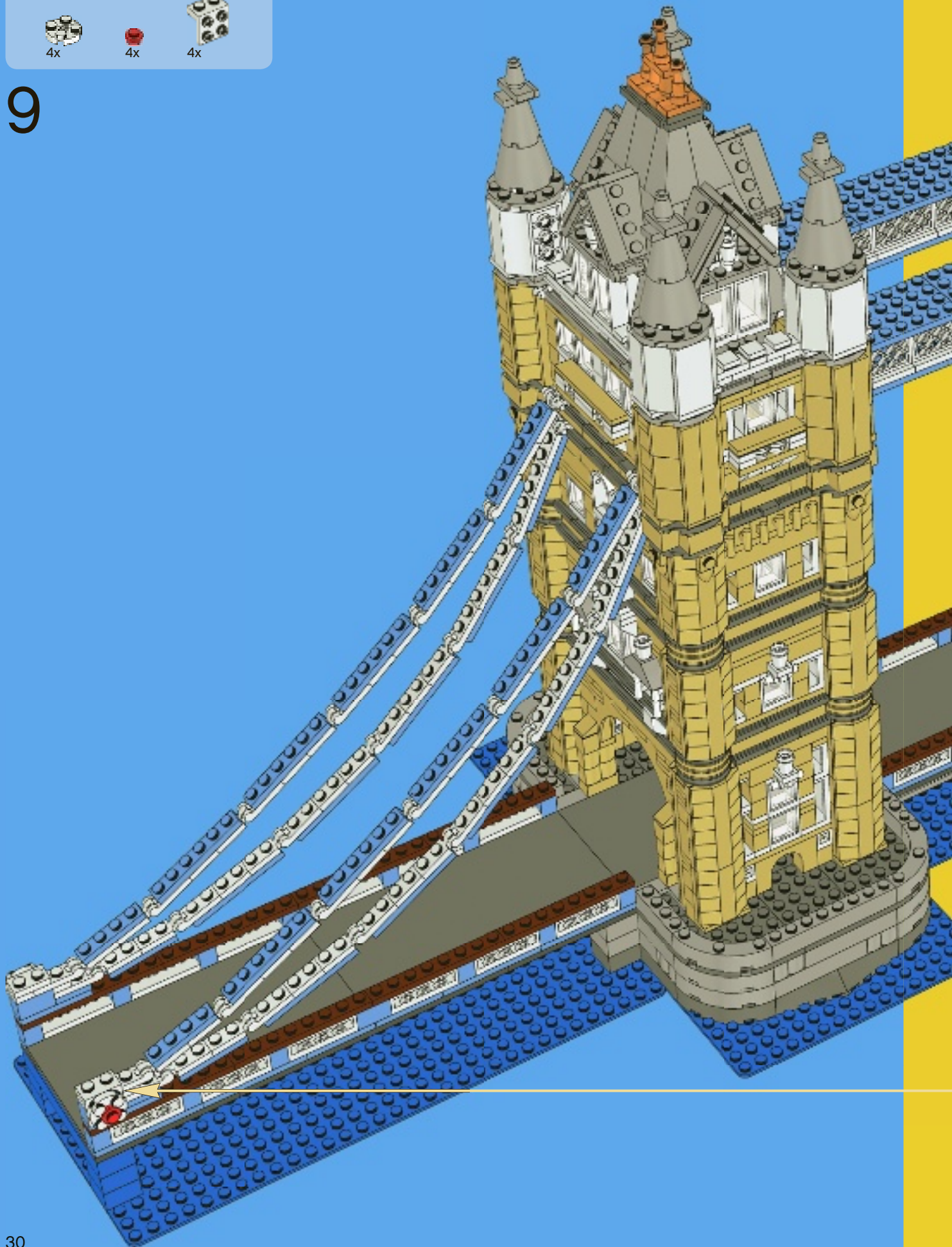

4x

9

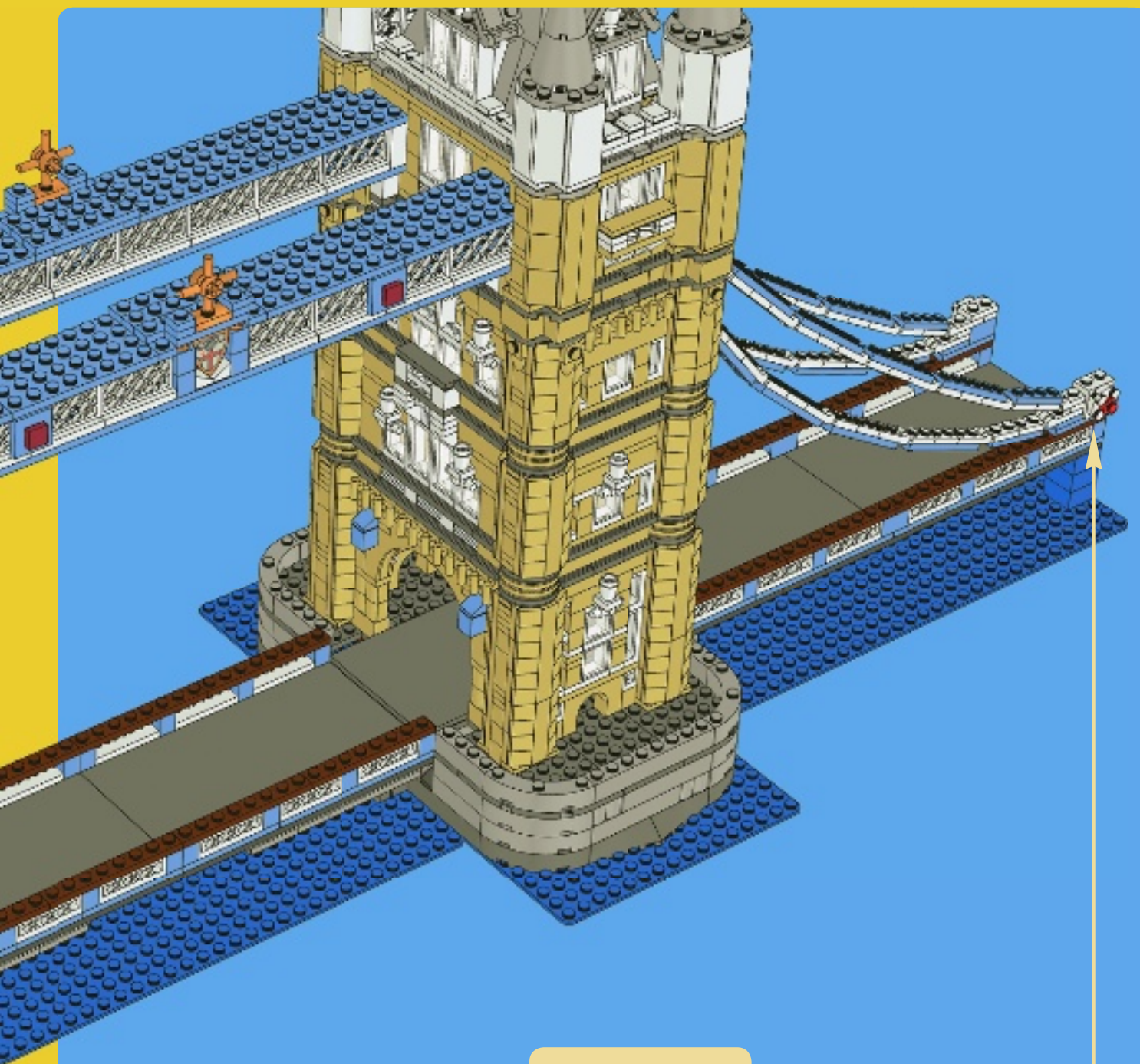



1 

2  4x



2x



1x

1

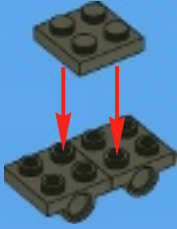

4x



2x

2



2x



4x

3



1x



1x

4

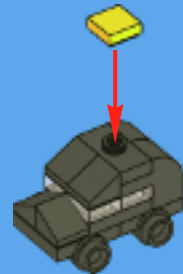



1x



2x

1

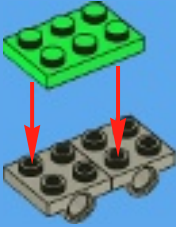

1x



4x

2

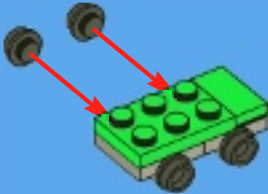

1x



2x

3



1x



2x

4





1

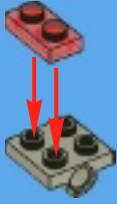

2



4x

3

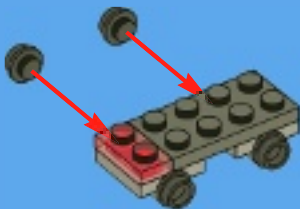

4

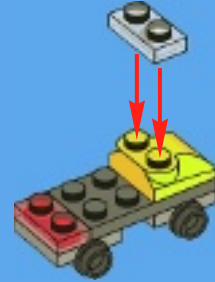

5



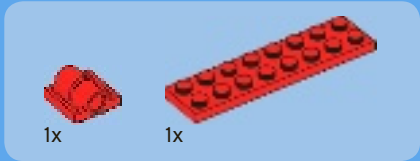

1

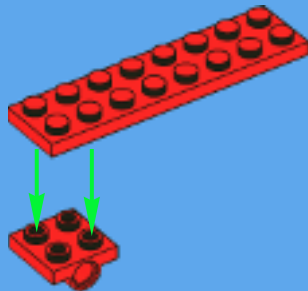

2

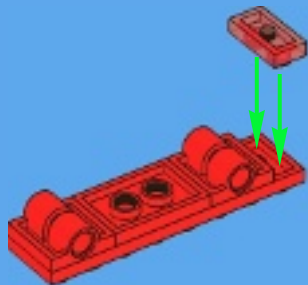

3

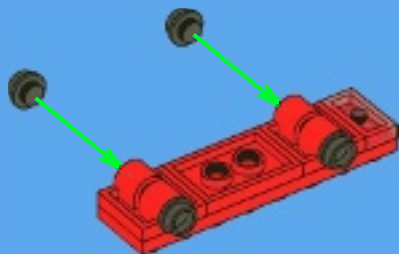



2x



1x



2x

4

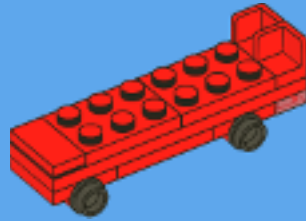

12x



1x

5

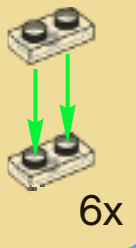

6x

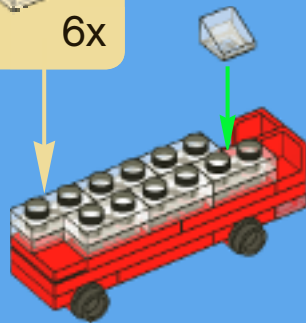

2x



1x

6

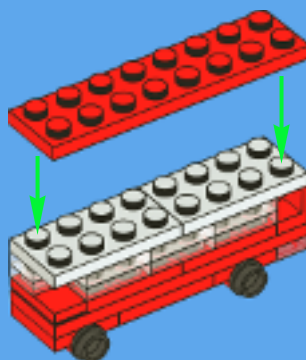



14x

7

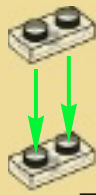

7x

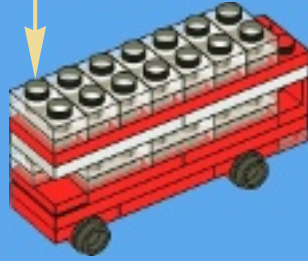

2x



2x

8



1x

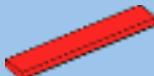

2x

9



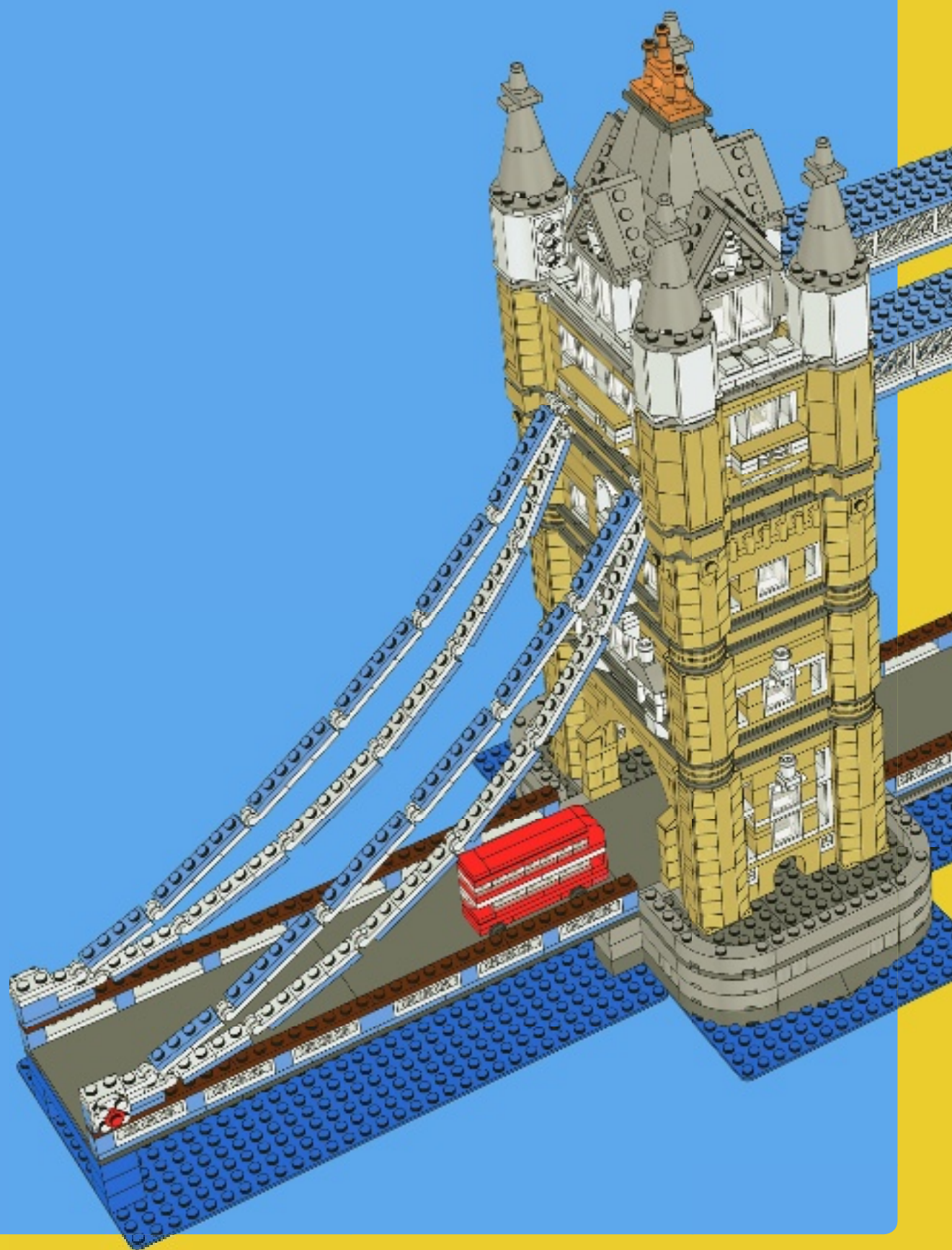

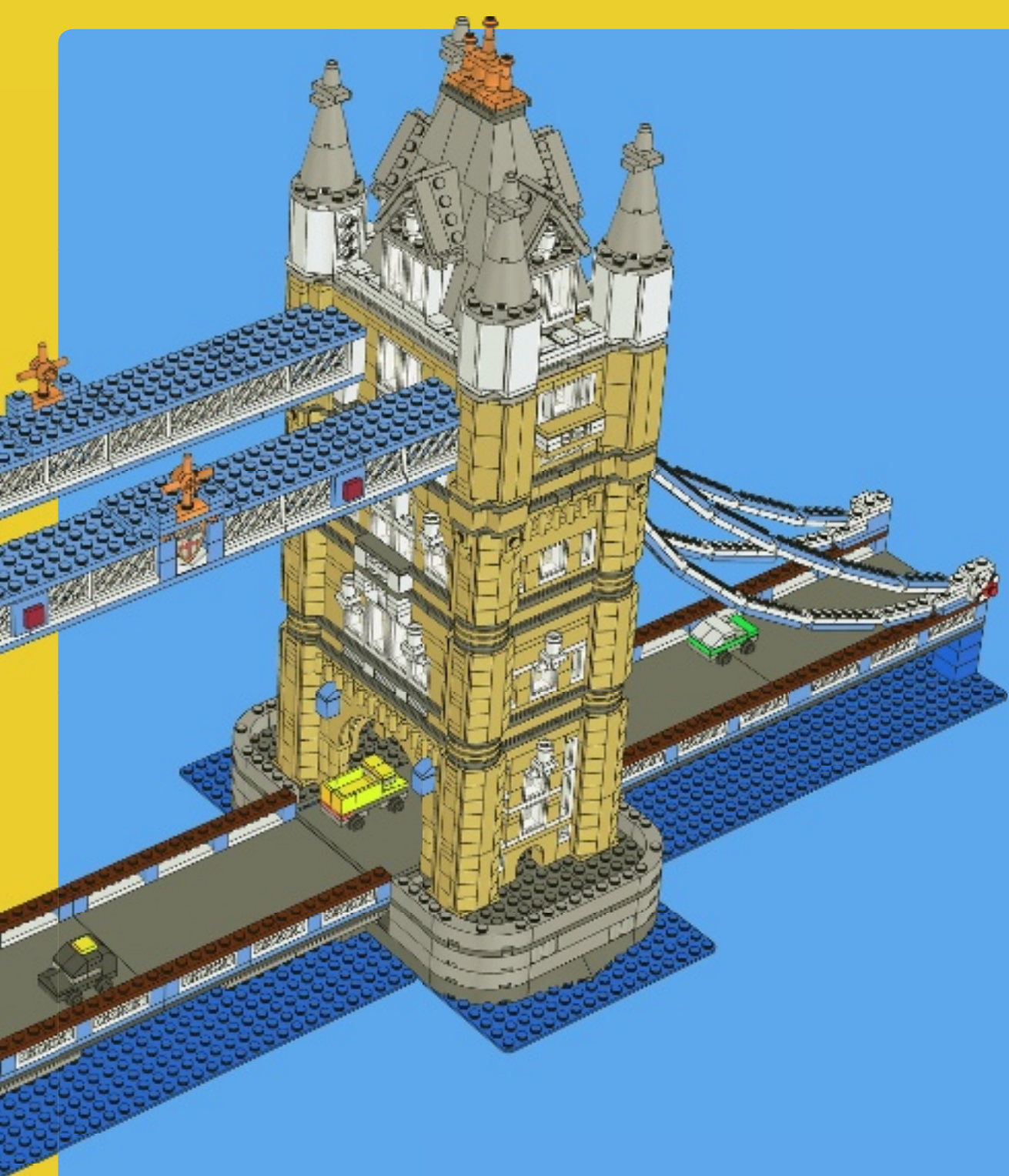

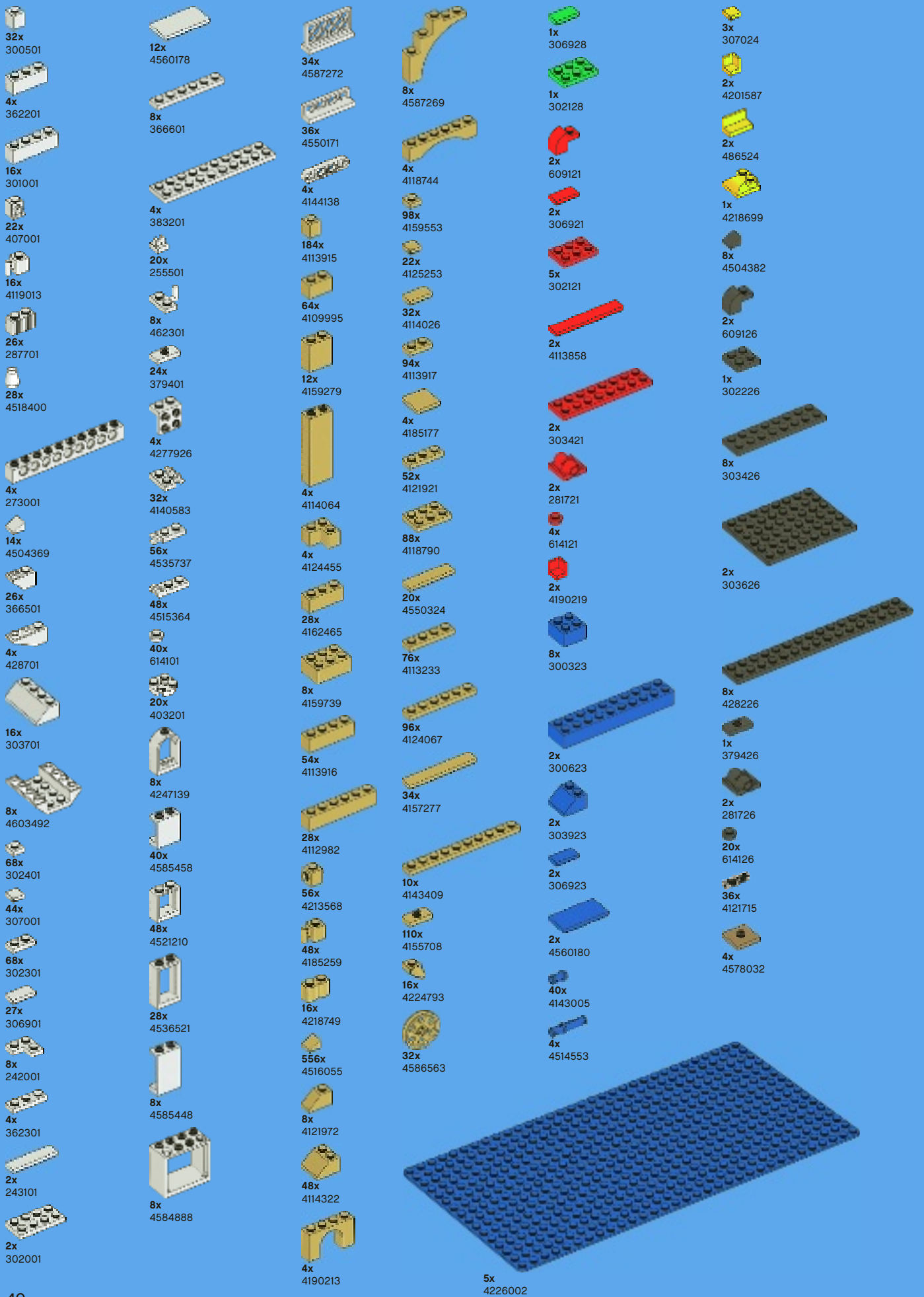

32x 300501
 4x 362201
 16x 301001
 22x 407001
 16x 4119013
 26x 287701
 28x 4518400
 4x 273001
 14x 4504369
 26x 366501
 4x 428701
 16x 303701
 8x 4603492
 68x 302401
 44x 307001
 68x 302301
 27x 306901
 8x 242001
 4x 362301
 2x 243101
 2x 302001

12x 4560178
 8x 366601
 4x 383201
 20x 255501
 8x 462301
 24x 379401
 4x 4277926
 32x 4140583
 56x 4535737
 48x 4515364
 40x 614101
 20x 403201
 8x 4247139
 40x 4585458
 48x 4521210
 28x 4536521
 8x 4585448
 8x 4584888

34x 4587272
 36x 4550171
 4x 4144138
 184x 4113915
 64x 4109995
 12x 4159279
 4x 4114064
 4x 4124455
 28x 4162465
 8x 4159739
 54x 4113916
 28x 4112982
 56x 4213568
 48x 4185259
 16x 4218749
 556x 4516055
 8x 4121972
 48x 4114322
 4x 4190213

8x 4587269
 4x 4118744
 98x 4159553
 22x 4125253
 32x 4114026
 94x 4113917
 4x 4185177
 52x 4121921
 88x 4118790
 20x 4550324
 76x 4113233
 96x 4124067
 34x 4157277
 10x 4143409
 110x 4155708
 16x 4224793
 32x 4586563

1x 306928
 1x 302128
 2x 609121
 2x 306921
 5x 302121
 2x 4113858
 2x 303421
 2x 281721
 4x 614121
 2x 4190219
 8x 300323
 2x 300623
 2x 303923
 2x 306923
 2x 4560180
 40x 4143005
 4x 4514553

3x 307024
 2x 4201587
 2x 486524
 1x 4218699
 8x 4504382
 2x 609126
 1x 302226
 8x 303426
 2x 303626
 8x 428226
 1x 379426
 2x 281726
 20x 614126
 36x 4121715
 4x 4578032

5x 4226002

3x
4244362

30x
4167842

48x
4552035

28x
4536998

2x
4201019

40x
4179830

20x
4179833

4x
4565363

8x
4179826

28x
4179825

32x
4179828

70x
4179829

18x
4587271

6x
4581079

4x
4550169

26x
4211201

24x
4216945

14x
4211387

24x
4211394

8x
4211385

14x
4211393

16x
4211392

2x
4211390

104x
4558953

12x
4550325

8x
4529241

8x
4211471

24x
4215472

8x
4497653

8x
4211494

24x
4191414

16x
4211684

4x
4251563

2x
4509914

14x
4211414

24x
4211397

4x
4211429

16x
4211356

20x
4211438

2x
4211406

8x
4251149

18x
4211451

16x
4556157

10x
4211568

16x
4244627

4x
4211376

8x
4211472

4x
4211498

8x
4211732

8x
4211735

16x
4515351

4x
4211352

2x
4582980

4x
4211103

6x
4211100

18x
4211095

8x
4211046

8x
4535931

4x
4211111

2x
4210917

4x
4298583

4x
4298580

8x
4211052

8x
4210635

4x
4211043

4x
4211001

4x
4211053

3x
4211065

4x
4243831

4x
4211002

8x
4211115

8x
4211119

8x
4210763

140x
4543086

10x
4210967

16x
4528323

8x
4500517

32x
4587275

8x
4596898

4x
4529247

12x
4523157

4x
4523159

6x
4538126

2x
4587274

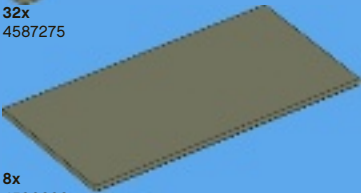

Customer Service
Kundenservice
Service Consommateurs
Servicio Al Consumidor

www.lego.com/service or dial

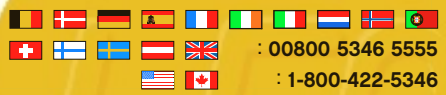

: 00800 5346 5555
: 1-800-422-5346



10185

10197

10211

FREE! GRATIS! GRATUIT!

LEGO

club
MAGAZINE™

www.LEGOclub.com



00800 5346 5555*



1-866-534-6258 • 1-877-518-5346

US & Canada only

Canada seulement

* FreePhone. Mobile charges may apply. * Numéro sans Frais. Des Frais peuvent s'appliquer avec les téléphones cellulaires. * Gebührenfrei, Kosten für Anrufe aus Mobilfunknetzen können abweichen.
* Gratis telefonnummer vanaf vaste lijn. * Det er et gratis nummer, når du ringer fra FastTelefon. * Det er gratis, når du ringer från en Fast telefon.



**VISIT THE WORLD'S
BIGGEST LEGO® SHOP!**

www.LEGOshop.com



WIN!

Go to www.nielsen.com/LEGO to fill out a survey for a chance to win a cool LEGO® Product. No purchase necessary. Open to all residents where not prohibited.

 www.LEGO.com



www.nielsen.com/LEGO

GEWINNE!

Nimm an der Umfrage auf www.nielsen.com/LEGO teil und hab die Chance ein cooles LEGO® Produkt zu gewinnen!

Die Teilnahme am Gewinnspiel führt zu keinerlei Kaufverpflichtungen. Teilnahme in allen nicht ausgeschlossenen Ländern möglich.

4611753 / 4658002

WIN!

Ga naar www.nielsen.com/LEGO, vul een enquêteformulier in en maak kans op een cool LEGO® product.

Geen aankoopverplichting. Iedereen mag deelnemen, uitgezonderd ingezetenden van landen waar een enquêteverbod geldt.

GAGNE !

Visite www.nielsen.com/LEGO pour répondre à un questionnaire et avoir une chance de gagner un produit LEGO® très cool !

Aucune obligation d'achat. Ouvert à tous les résidents des pays autorisés.

当てよう!

www.nielsen.com/LEGOにアクセスして、アンケートにご記入ください。当選者にはレゴ®製品を差し上げます。

お買い上げの必要はありません。禁止されていない限り、すべての皆様にご利用いただけます。